

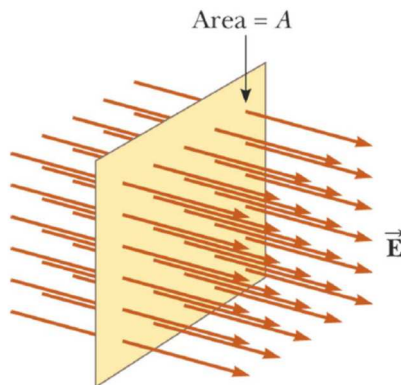
**Chapter 23**  
**Gauss' Law**  
**Masatsugu Sei Suzuki**  
**Department of Physics, SUNY at Binghamton**  
**(Date; August 15, 2020)**

**1. Flux of an electric field**

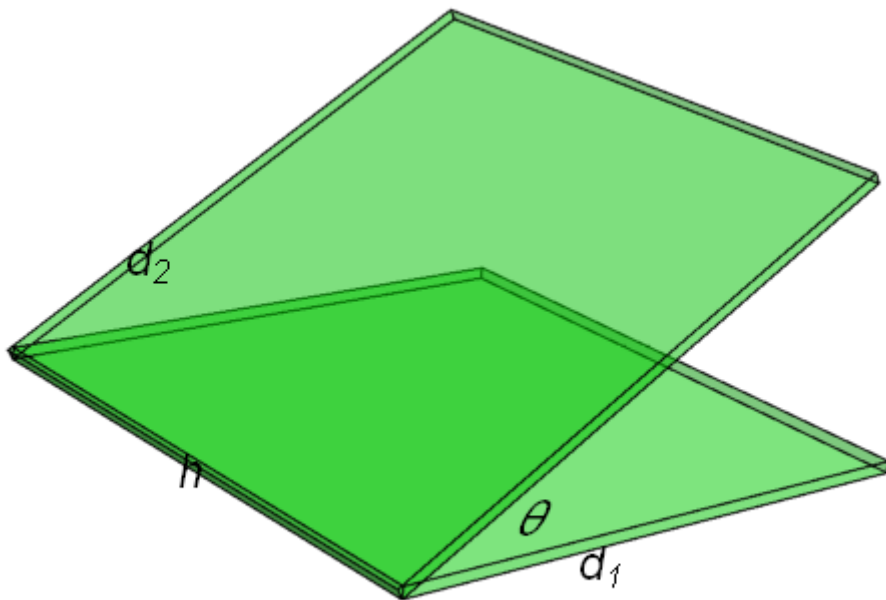
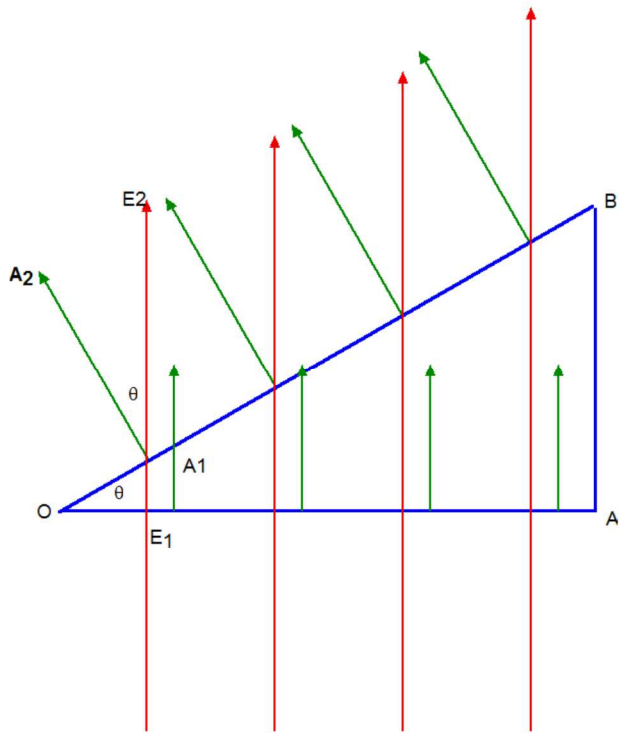
Electric flux is a quantity proportional to the number of electric field lines penetrating some surface. The electric flux of the electric field  $\mathbf{E}$  through the surface area,  $d\mathbf{A}$ , is defined as.

$$d\Phi = \mathbf{E} \cdot d\mathbf{A} = EdA \cos \theta$$

where  $\theta$  is the angle between  $\mathbf{E}$  and  $d\mathbf{A}$ .  $d\mathbf{A}$  is a vector directed perpendicular to the area. The magnitude of  $d\mathbf{A}$ . The unit of the electric flux  $\Phi$  is  $\text{Nm}^2/\text{C}$



Electric field lines penetrating a plane of area  $A$  perpendicular to the field.



**Fig.**  $A_1 = d_1 h$ .  $A_2 = d_2 h$ .  $d_2 = d_1 \cos \theta$ .  $A_2 = A_1 \cos \theta$

The electric flux passing through surface  $A_1$  is

$$\Phi_1 = E_1 A_1.$$

The electric flux passing through surface  $A_2$  is given by

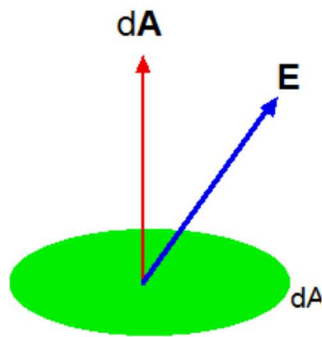
$$\Phi_2 = \mathbf{E}_2 \cdot \mathbf{A}_2 = E_2 A_2 \cos \theta.$$

Since  $E_1 = E_2$ , and  $A_1 = A_2 \cos \theta$ , we have

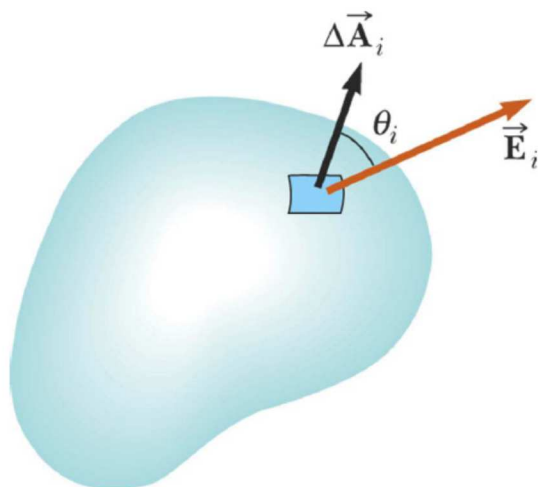
$$\Phi_2 = \Phi_1.$$

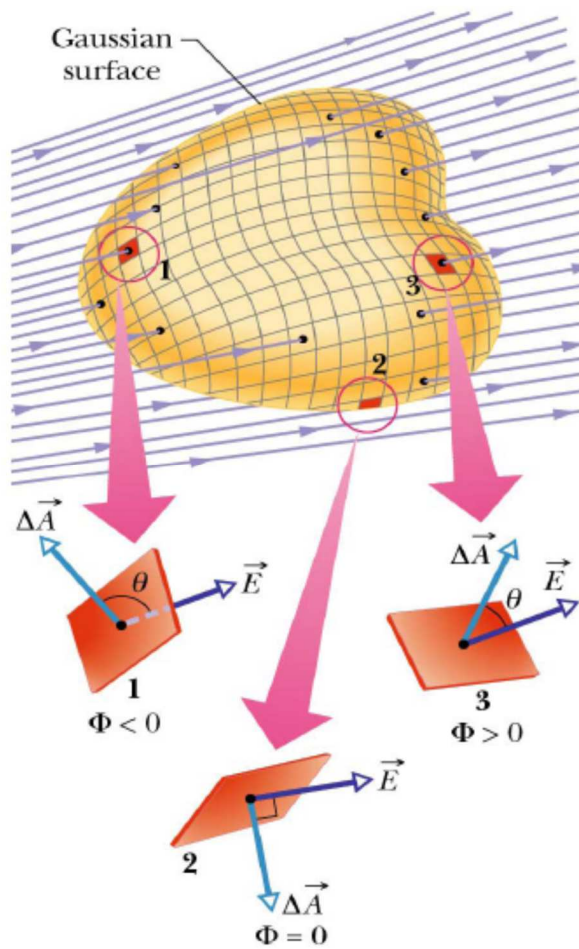
The total flux through a closed surface  $A$  is

$$\Phi = \oint \mathbf{E} \cdot d\mathbf{A}.$$



$$d\Phi = \mathbf{E} \cdot d\mathbf{A}$$

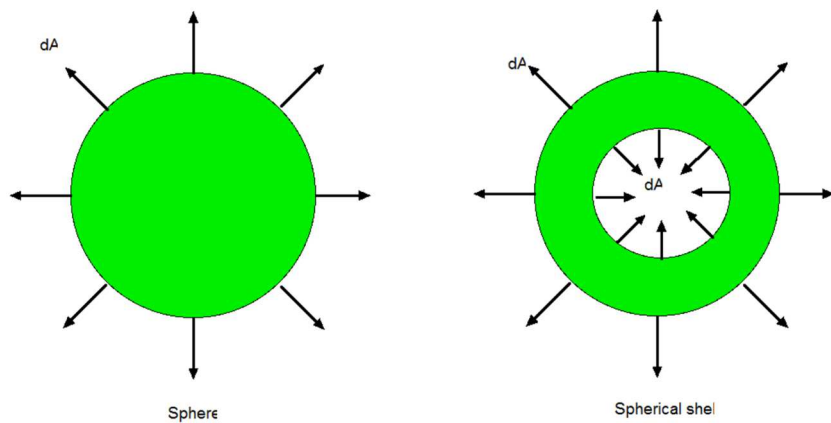




A closed surface in an electric field.

**((Note))** Electric field in a closed surface

The direction of  $dA$  is shown for the sphere and the spherical shell as follows.



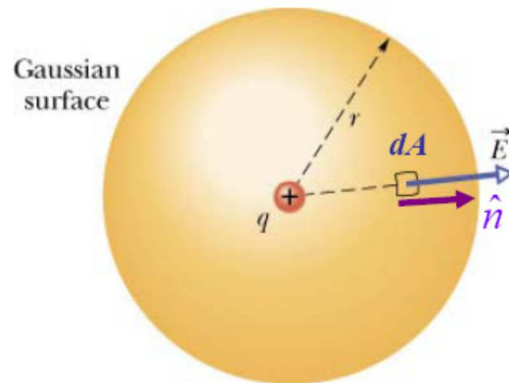
## 2. Gauss' law

Gauss' law is an expression of the general relationship between the net electric flux through a closed surface and the charge enclosed by the surface. The closed surface is often called a **Gaussian surface**.

If the Gaussian surface has a net electric charge  $q_{in}$  within it, then the electric flux through the surface is  $q_{in}/\epsilon_0$ , that is

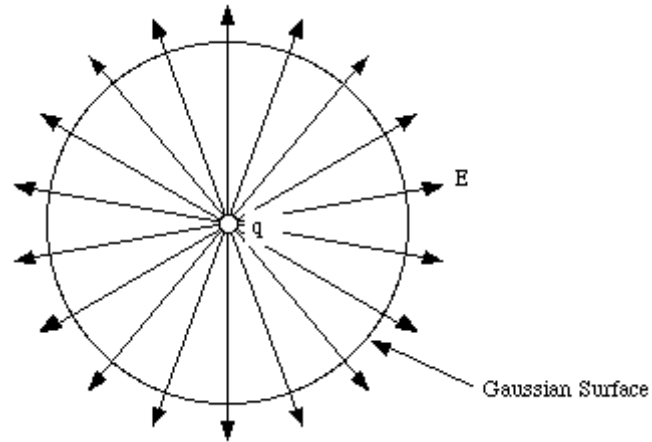
$$\Phi = \oint \mathbf{E} \cdot d\mathbf{A} = \frac{q_{in}}{\epsilon_0}$$

## 3. Gauss' law and Coulomb's law



The field generated by a point charge  $q_{in} = q$  is spherical symmetric, and its magnitude will depend only on the distance  $r$  from the point charge. The direction of the field is along the radial direction. Consider a spherical surface centered around the point charge  $q$ . The direction of the electric field at any point on its surface is perpendicular to the surface and its magnitude is constant. This implies that the electric flux  $\Phi$  through this surface is given by

$$\Phi = \oint \mathbf{E} \cdot d\mathbf{A} = 4\pi r^2 E$$



**Fig.** Electric field generated by point charge  $q$ .

Using Gauss' law we obtain the following expression

$$\Phi = 4\pi r^2 E = \frac{q}{\epsilon_0},$$

or

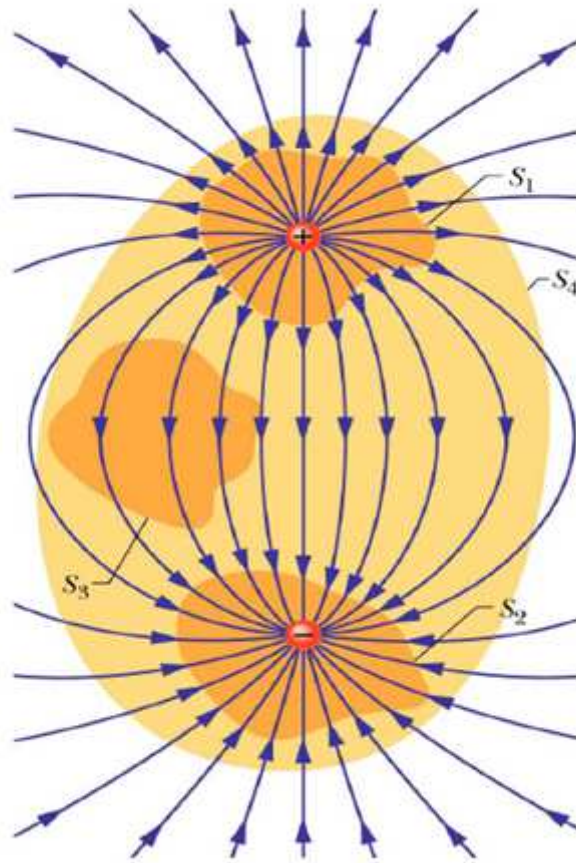
$$E = \frac{1}{4\pi\epsilon_0} \frac{q}{r^2},$$

which is Coulomb's law.

---

**((Note))**

What is the electric flux for each surface?



Gaussian surface  $S_1$

$$\Phi = \oint \mathbf{E} \cdot d\mathbf{A} = \frac{q_{in}}{\epsilon_0} = \frac{q}{\epsilon_0} \quad (\text{outward})$$

Gaussian surface  $S_2$

$$\Phi = \oint \mathbf{E} \cdot d\mathbf{A} = \frac{q_{in}}{\epsilon_0} = \frac{-q}{\epsilon_0} \quad (\text{inward})$$

Gaussian surface  $S_3$

$$\Phi = \oint \mathbf{E} \cdot d\mathbf{A} = \frac{q_{in}}{\epsilon_0} = 0$$

Gaussian surface  $S_4$

$$\Phi = \oint \mathbf{E} \cdot d\mathbf{A} = \frac{q_{in}}{\epsilon_0} = 0$$

### 3. Application of the Gauss' law: spherical symmetry

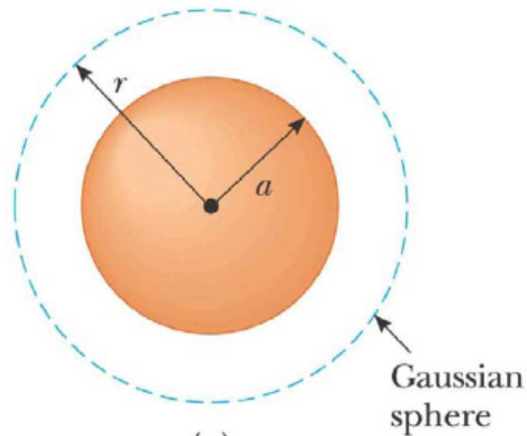
A spherical region of radius  $a$  has a total charge  $Q$ , distributed uniformly throughout the volume of this region.

- What is the electric field at point outside the sphere?
- What is the electric field at points inside the sphere?

For  $r > a$ ,

$$\Phi = \oint \mathbf{E} \cdot d\mathbf{A} = \frac{q_{in}}{\epsilon_0} = \frac{Q}{\epsilon_0}$$

$$E \cdot (4\pi r^2) = \frac{Q}{\epsilon_0}, \quad \text{or} \quad E = \frac{1}{4\pi\epsilon_0} \frac{Q}{r^2}$$



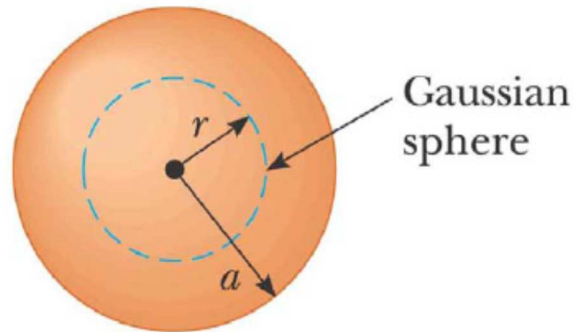
For  $r < a$ ,

The charge density  $\rho$  is given by

$$\rho = \frac{Q}{\frac{4\pi}{3}a^3}$$

We select a sphere with a radius  $r$  ( $<a$ ) as the Gaussian surface.





$$\Phi = \oint \mathbf{E} \cdot d\mathbf{A} = \frac{q_{in}}{\epsilon_0},$$

where

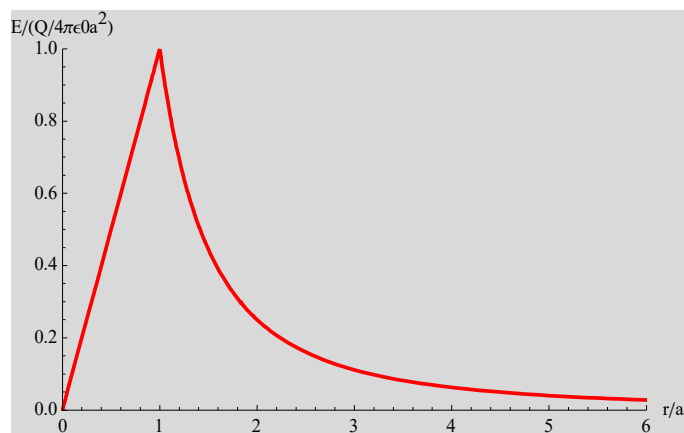
$$q_{in} = \frac{4\pi}{3} r^3 \rho = \frac{4\pi}{3} r^3 \frac{Q}{\frac{4\pi}{3} a^3} = Q \frac{r^3}{a^3}.$$

Then we have

$$E(4\pi r^2) = \frac{Q}{\epsilon_0} \frac{r^3}{a^3}, \quad \text{or} \quad E = \frac{Q}{4\pi\epsilon_0} \frac{r}{a^3}.$$

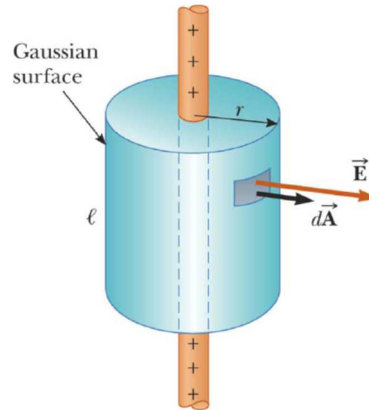
In conclusion.

Inside the sphere,  $E$  varies linearly with  $r$ .  $E \rightarrow 0$  as  $r \rightarrow 0$ . The field outside the sphere is equivalent to that of a point charge located at the center of the sphere



**Fig.** Magnitude of the electric field ( $E/(Q/4\pi\epsilon_0 a^2)$ ) as a function of the radial distance  $r$  for a uniformly charged sphere with radius  $a$ .

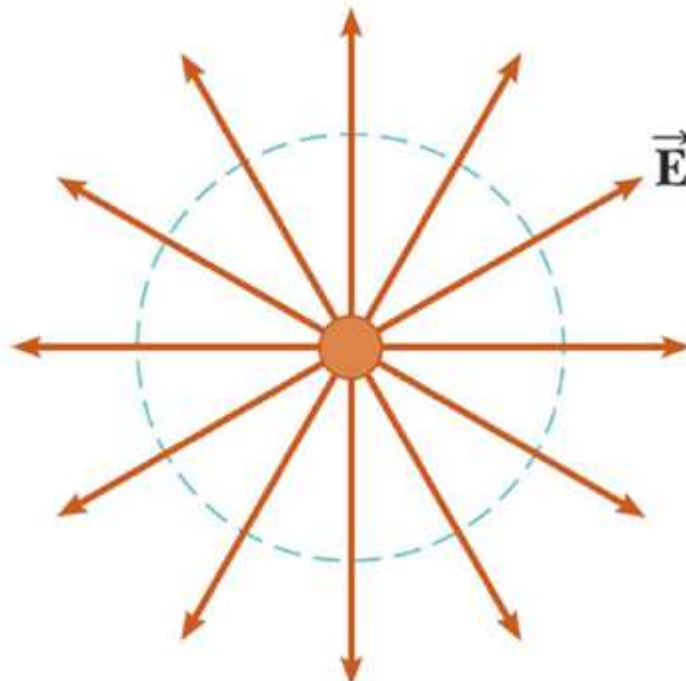
#### 4. Application of the Gauss' law: cylindrical symmetry



Using Gauss' law, find the electric field of an infinitely long, thin straight rod of charge, with uniform charge density  $\lambda$ .

The cylinder has a radius of  $r$  and a length of  $\ell$ .  $E$  is constant in magnitude and perpendicular to the surface at every point on the curved part of the surface.

The end view confirms the field is perpendicular to the curved surface. The field through the ends of the cylinder is 0 since the field is parallel to these surfaces.

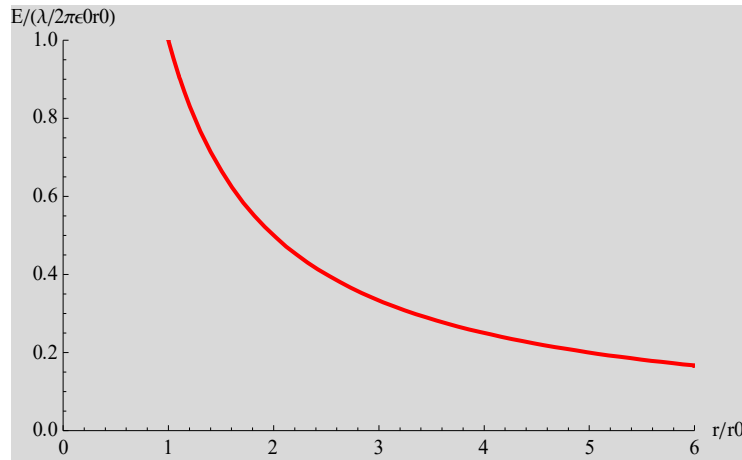


Use the Gauss' law to find the field,

$$\Phi = \oint \mathbf{E} \cdot d\mathbf{A} = E(2\pi rl) = \frac{\lambda l}{\epsilon_0},$$

or

$$E = \frac{\lambda}{2\pi\epsilon_0 r}.$$

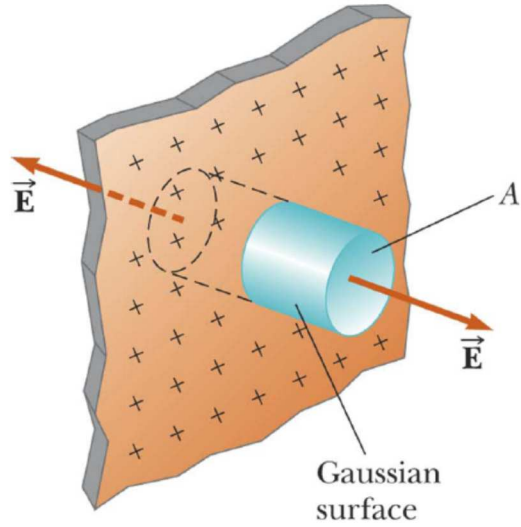


**Fig.** Magnitude of the electric field as a function of radial distance  $r$  for an infinitely long, thin straight rod of charge, with uniform charge density  $\lambda$ .

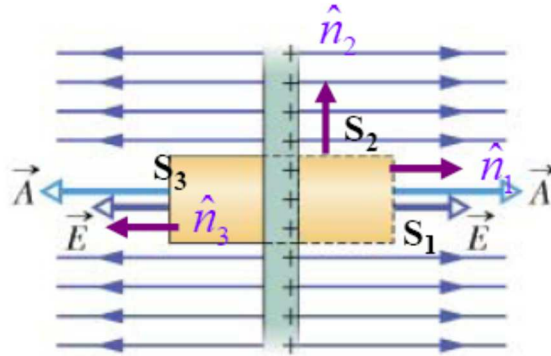
## 5. Application of the Gauss' law: planar symmetry

### (a) Nonconducting sheet

Using the Gauss' law, find the electric field of a very large uniform sheet of charge with the surface charge density  $\sigma$  (units of  $C/m^2$ ) (*nonconducting sheet*).



© 2008 Brooks/Cole - Thomson



We use the Gauss' law for this configuration.

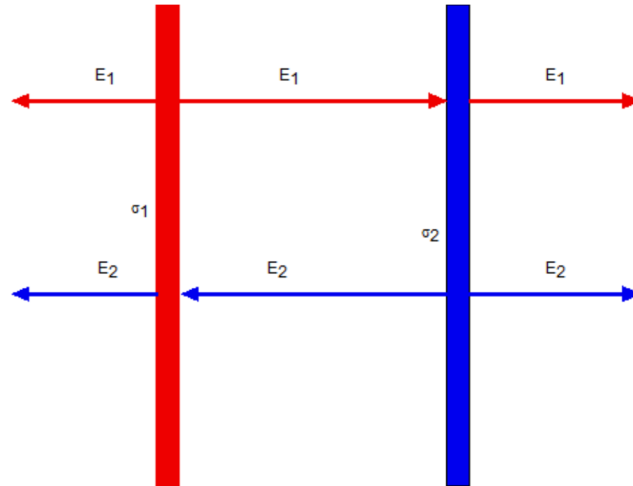
$$\Phi = \oint \vec{E} \cdot d\vec{A} = EA + EA = \frac{\sigma A}{\epsilon_0},$$

or

$$E = \frac{\sigma}{2\epsilon_0}.$$

**(b) Two nonconducting sheets**

We consider two large, parallel, nonconducting sheets (1 and 2), each with a fixed uniform charge on the sheet. The surface charge density of the sheet 1 and sheet 2 is  $\sigma_1$  and  $\sigma_2$ , respectively.



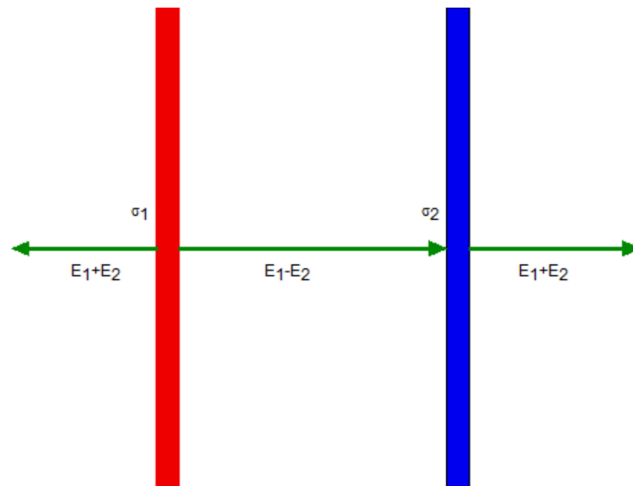
Applying the Gauss' law to the sheet 1 and sheet 2 independently, we have  $E_1$  and  $E_2$  given by

$$E_1 = \frac{\sigma_1}{2\epsilon_0}, \quad \text{and} \quad E_2 = \frac{\sigma_2}{2\epsilon_0}.$$

Using the superposition principle, we obtain the resultant electric field

$$E_1 + E_2 = \frac{\sigma_1}{2\epsilon_0} + \frac{\sigma_2}{2\epsilon_0} \quad \text{for the right of the sheets and for the left of the sheets}$$

$$E_1 - E_2 = \frac{\sigma_1}{2\epsilon_0} - \frac{\sigma_2}{2\epsilon_0} \quad \text{between the two sheets}$$



(i) For  $\sigma_1 = -\sigma_2 = \sigma$

$$E_1 + E_2 = 0$$

$$E_1 - E_2 = \frac{\sigma}{\epsilon_0}$$

(ii) For  $\sigma_1 = \sigma_2 = \sigma$

$$E_1 + E_2 = \frac{\sigma}{\epsilon_0}$$

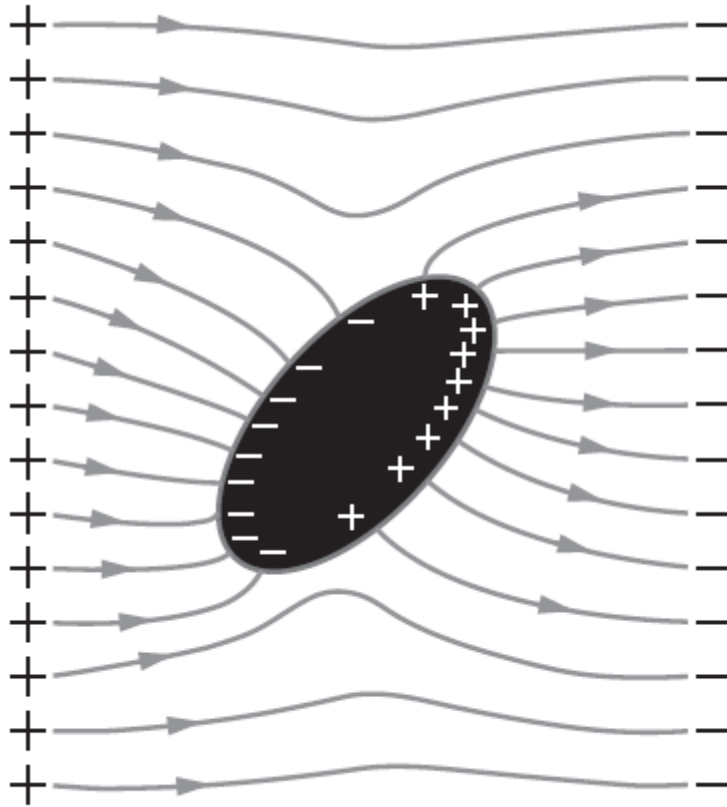
$$E_1 - E_2 = 0$$

## 6. Conductors in Electric Fields

A large number of electrons in a conductor are free to move. The so-called free electrons are the cause of the different behavior of conductors and insulators in an external electric field. The free electrons in a conductor will move under the influence of the external electric field (in a direction opposite to the direction of the electric field). The movement of the free electrons will produce an excess of electrons (negative charge) on one side of the conductor, leaving a deficit of electrons (positive charge) on the other side. This charge distribution will also produce an electric field and the actual electric field inside the conductor can be found by superposition of the external electric field and the induced electric field, produced by the induced charge distribution. When static equilibrium is reached, *the net electric field inside the conductor is exactly zero*. This implies that the charge density inside the conductor is zero. If the electric field inside the conductor would not be exactly zero the free electrons would continue to move and the charge distribution would not be in static equilibrium. *The electric field on the surface of the conductor is perpendicular to its surface*. If this would not be the case, the free electrons would move along the surface, and the charge distribution would not be in equilibrium. The redistribution of the free electrons in the conductor under the influence of an external electric field, and the cancellation of the external electric field inside the conductor is being used to shield sensitive instruments from external electric fields.

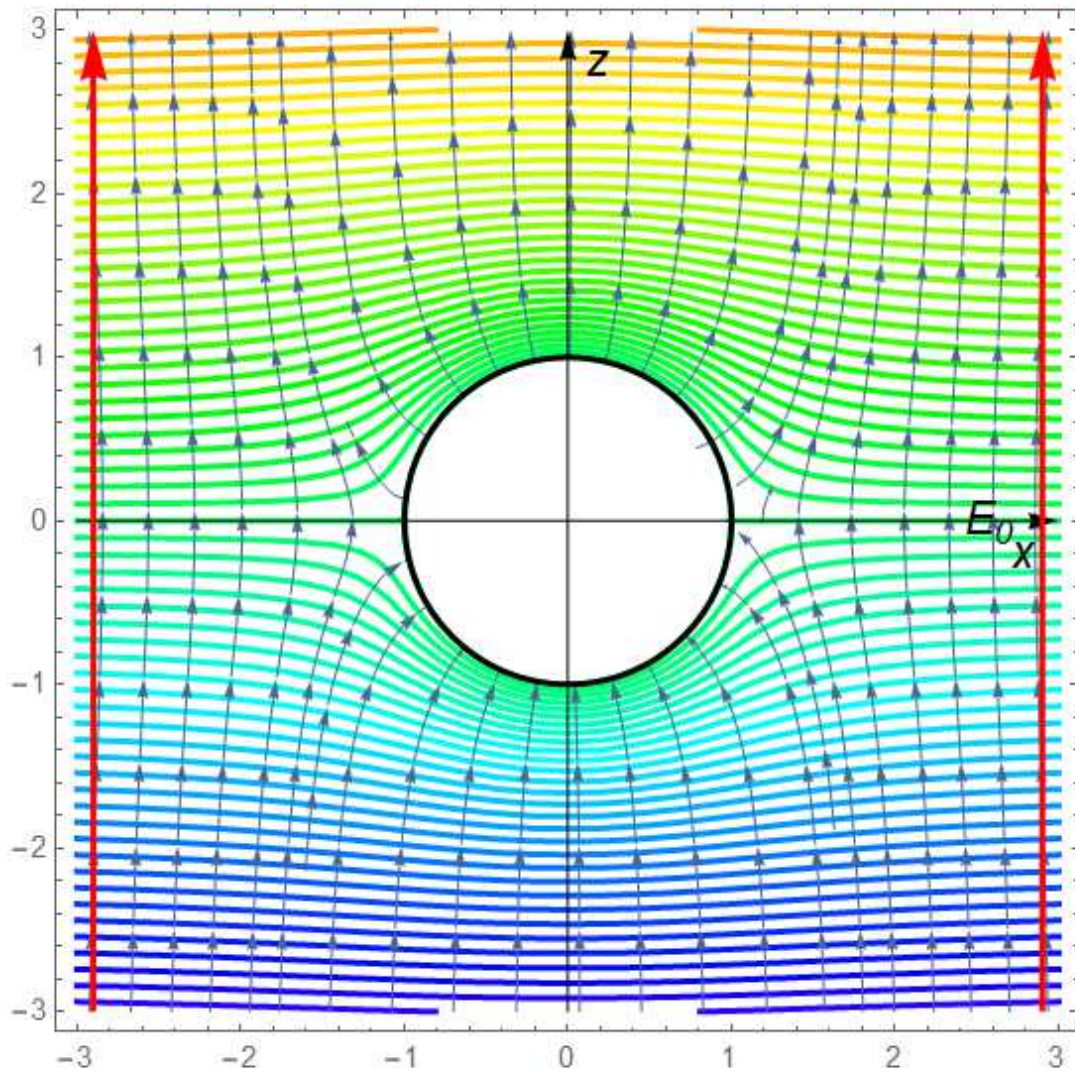
((Summary))

1.  $E = 0$  everywhere inside the conductor.
2. There is no net charge inside the conductor.
3.  $E$  is everywhere perpendicular to the bounding surface of the conductor.
4. The electric potential  $V$  is constant inside the conductor.
5. Any net charge must reside on the surface of conductor.
6. The tangential component of the electric field  $E$  is zero on the surface of conductor. Otherwise, charge will immediately flow around the surface until it kills off the tangential component. (Perpendicular to the surface, charge cannot flow, of course, since it is confined to the conducting object.)



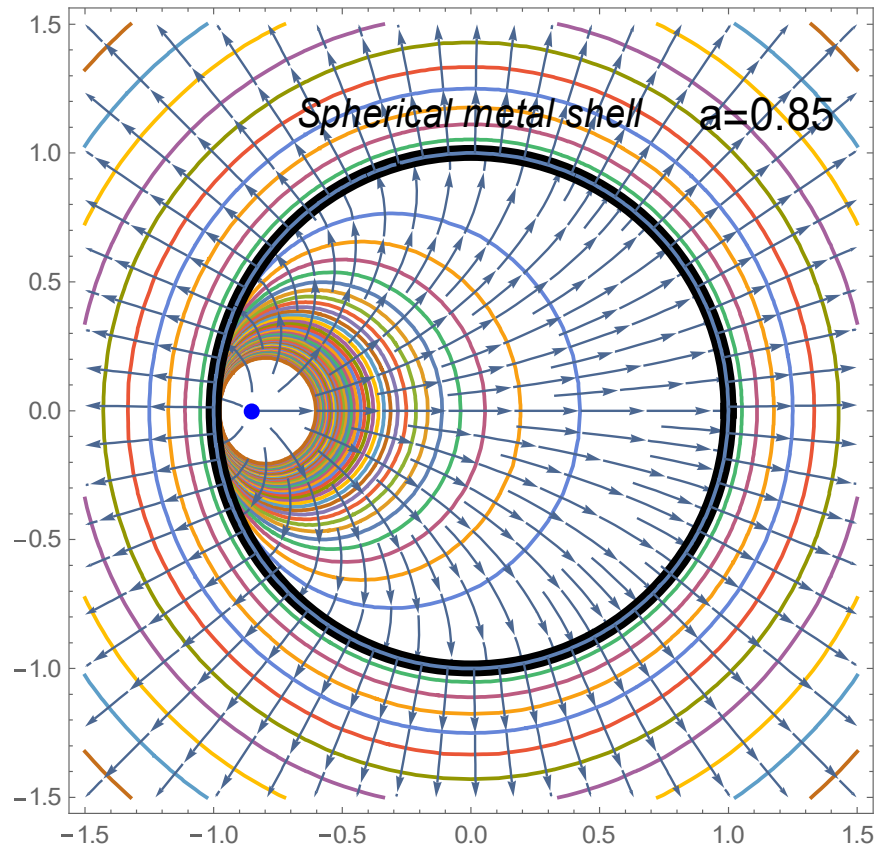
(v) **E is perpendicular to the surface, just outside a conductor.** Otherwise, as in (i), charge will immediately flow around the surface until it kills off the tangential component (Fig. 2.43). (*Perpendicular* to the surface, charge cannot flow, of course, since it is confined to the conducting object.)

**Fig.** The charge distribution at the surface of conductor, in the presence of a uniform electric field produced by two fixed layers of charge. [Fig.3.1(c), Purcell and Morin, *Electricity and Magnetism*, Cambridge, 2013].

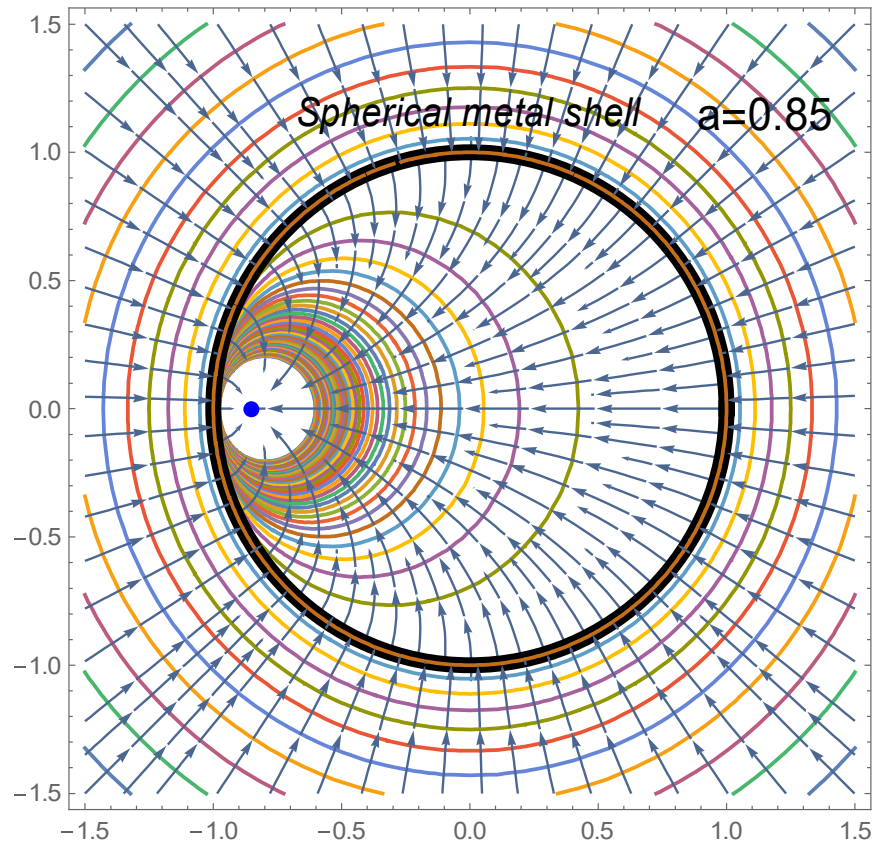


**Fig.** Electric field distribution for an uncharged metal sphere of radius  $R$  is placed in an otherwise uniform electric field  $\mathbf{E} = E_0 \mathbf{e}_x$ . The equi-potential line is also shown. The field will push positive charge on the northern surface of the sphere, leaving a negative charge on the southern surface. This induced charge, in turn, distorts the field in the neighborhood of the sphere. (This is obtained by using Mathematica; ContourPlot and StreamPlot).  $E_0 = 1$ .  $R = 1$ .

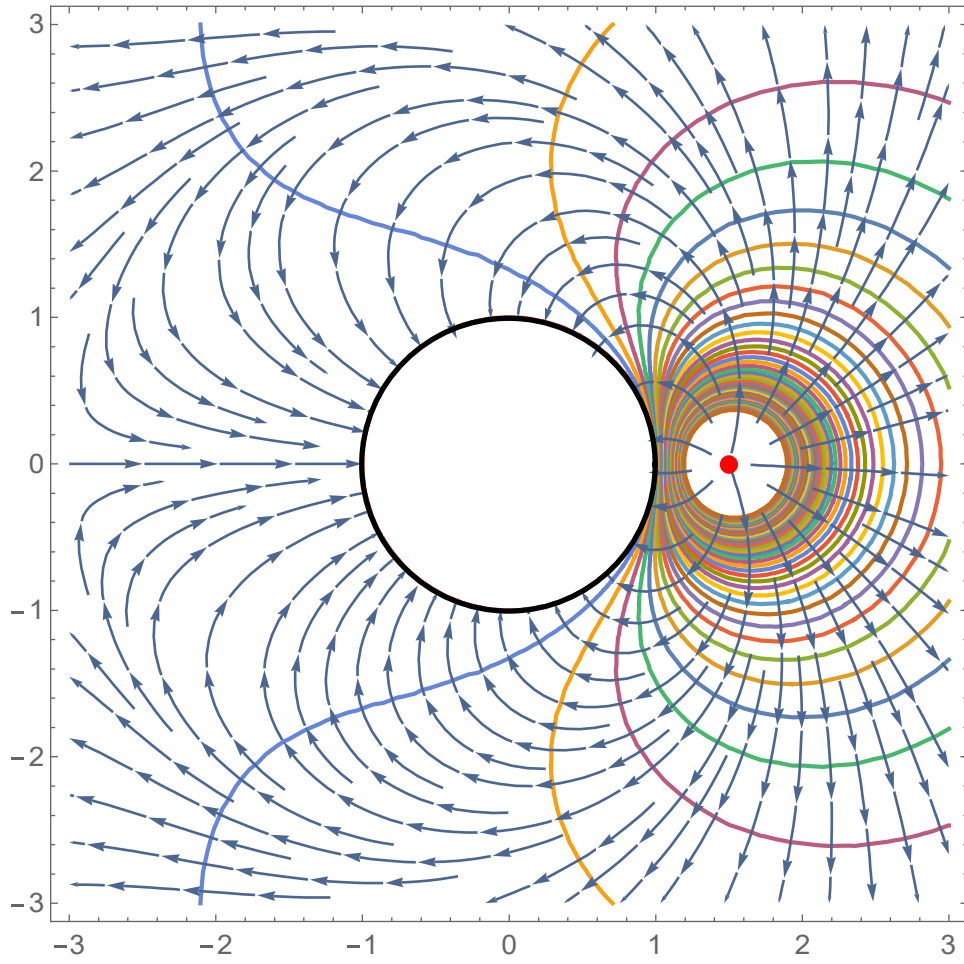




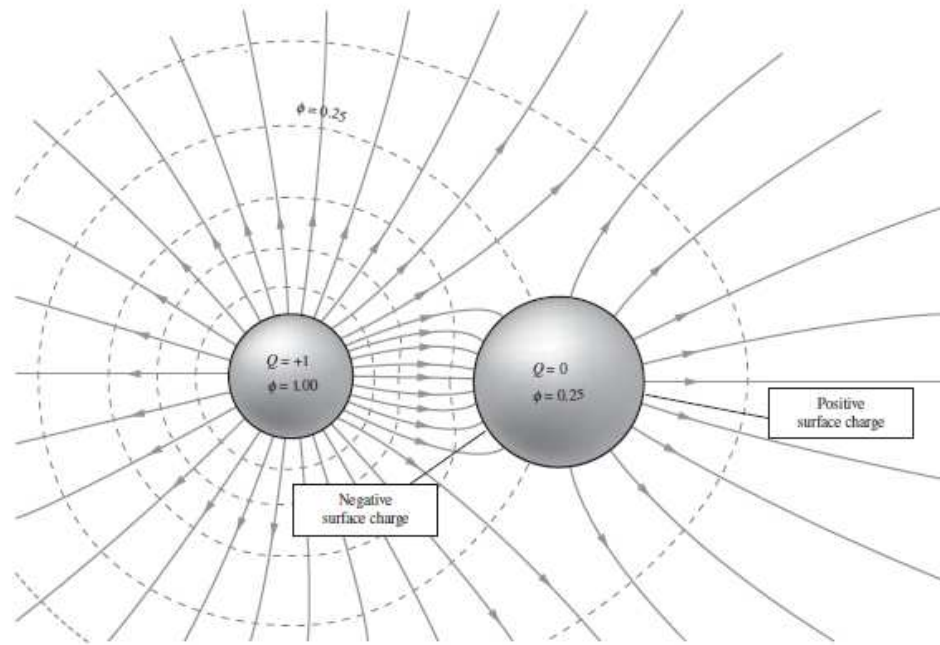
**Fig.** Electric field distribution inside a sphere conductor in which a point positive charge exists at  $x = -a$ .  $a = 0.85$ .  $q = 1$ .



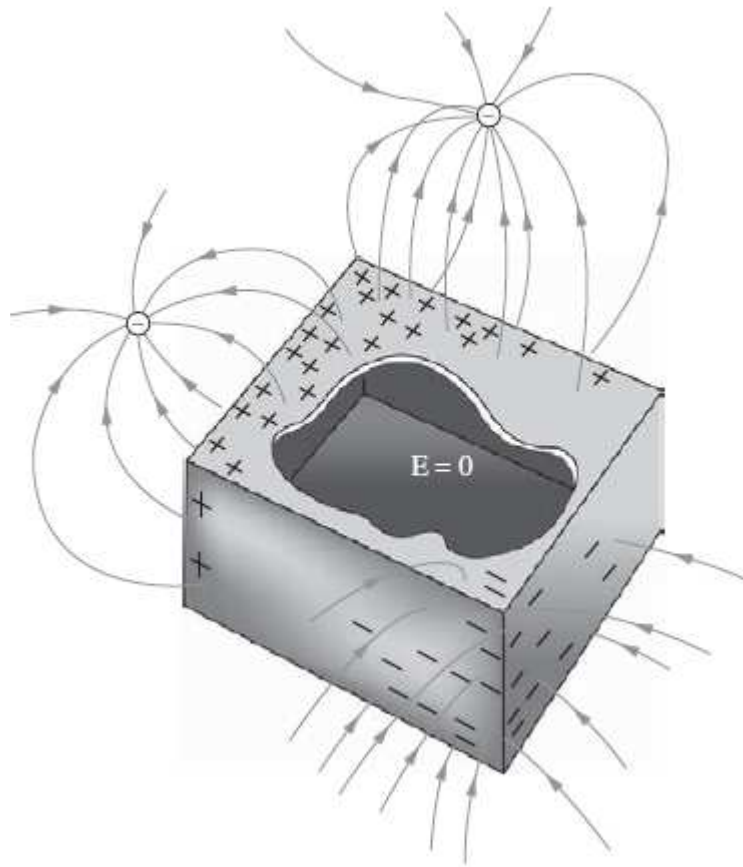
**Fig.** Electric field distribution inside a sphere conductor in which a point negative charge exists at  $x = -a$ .  $a = 0.85$ .  $q = -1$ .



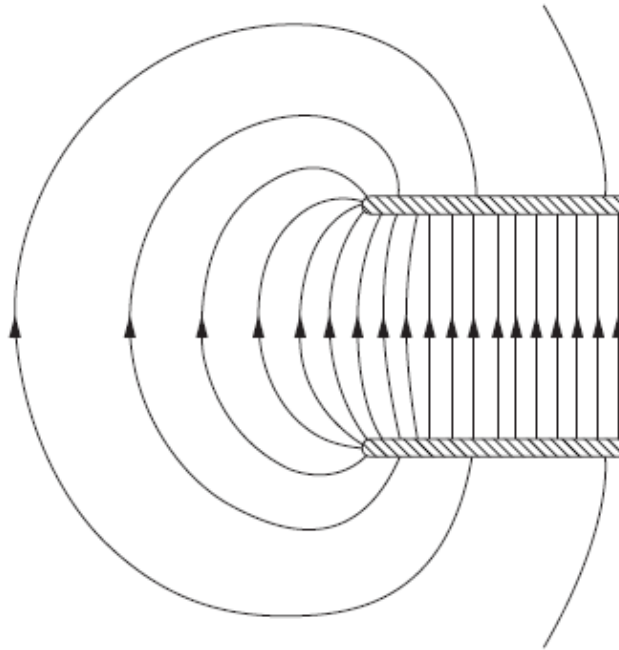
**Fig.** Electric field distribution around a sphere conductor due to a neighboring point positive charge



**Fig.** The electric field around two spherical conductors, one with the total charge +1, and one with total charge zero. Dashed curves are intersections of equipotential surfaces with the plane of the figure. Zero potential is at infinity. [Fig.3.7, Purcell and Morin, Electricity and Magnetism, Cambridge, 2013].



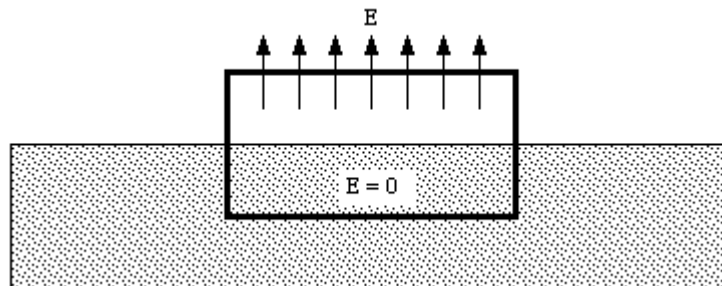
**Fig.** The field is zero everywhere inside a closed conducting box. [Fig.3.8, Purcell and Morin, Electricity and Magnetism, Cambridge, 2013].



**Fig.** The electric field near the edge of two parallel metal plates. (Feynman vol.2, Fig. 6-13).

### 7. Application of the Gauss' law to the surface of conductor

The strength of the electric field on the surface of a conductor can be found by applying Gauss' law).



The electric flux through the surface is given by

$$\Phi = AE + A \cdot 0 = AE$$

where  $A$  is the area of the top of the surface. The flux through the bottom of the surface is zero since the electric field inside a conductor is equal to zero. The charge enclosed by the surface is equal to

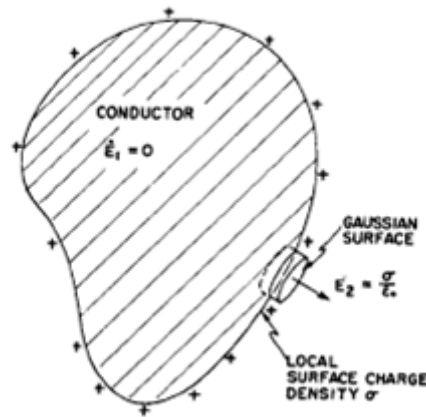
$$Q = A\sigma$$

where  $\sigma$  is the surface charge density of the conductor. Applying Gauss' law we obtain

$$\Phi = AE = \frac{Q}{\epsilon_0} = \frac{A\sigma}{\epsilon_0}.$$

Thus, the electric field at the surface of the conductor is given by

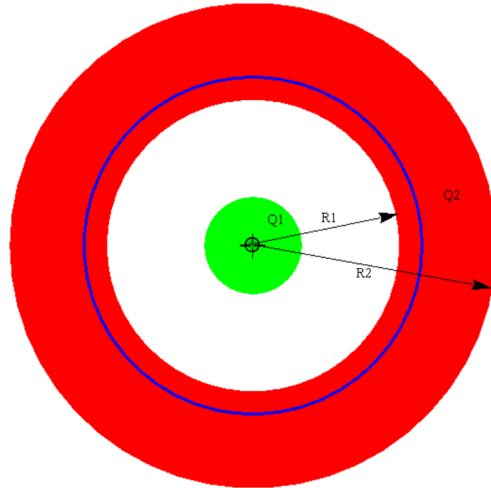
$$E = \frac{\sigma}{\epsilon_0}.$$



**Fig.** The electric field just outside the surface of a conductor is proportional to the local surface density of charge.

**((Example))**

A point charge  $Q_1$  is at the center of a spherical conducting shell of inner radius  $R_1$  and the outer radius  $R_2$ . The shell has a net charge  $Q_2$  on its surfaces. Find the electric field in the three regions  $r < R_1$ ,  $R_1 < r < R_2$ , and  $r > R_2$ . How much charge is on the inner surface of the shell? The outer surface?

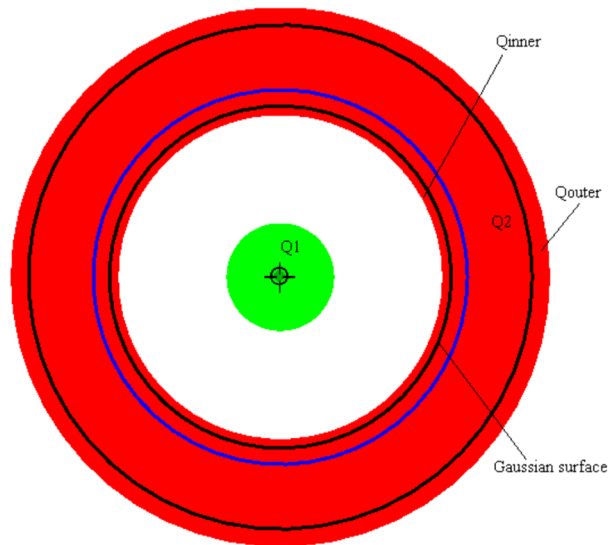


For  $r < R_1$ , the Gauss' law in spherical symmetry leads to the electric field given by

$$E = \frac{1}{4\pi\epsilon_0} \frac{Q_1}{r^2}.$$

For  $R_1 < r < R_2$ , because of the conductor, the electric field is equal to 0,  $E = 0$ . For  $r > R_2$ , the charge enclosed by the Gaussian surface is  $Q_1 + Q_2$ . The electric field is given by

$$E = \frac{1}{4\pi\epsilon_0} \frac{Q_1 + Q_2}{r^2}.$$



We choose the Gaussian sphere with a radius  $r$  ( $R_1 < r < R_2$ ) inside the conductor. Since the electric field is equal to zero in this region, the total charge inside the Gaussian surface should be equal to zero. When we assume that the surface charge around  $r = R_1$  is  $Q_{\text{inner surface}}$ , the Gauss' law leads to



$$\oint \mathbf{E} \cdot d\mathbf{A} = \frac{Q_{\text{inner-surface}} + Q_1}{\epsilon_0} = 0,$$

or

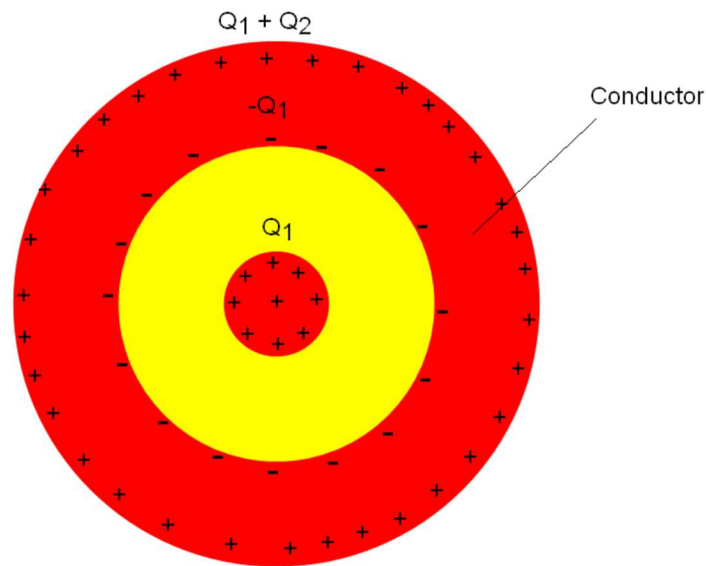
$$Q_{\text{inner-surface}} = -Q_1.$$

We say that the charge  $Q_1$  induces an equal but opposite charge on the inner surface of the conductor. To find the charge on the outer, we merely use conservation of charge.

$$Q_2 = Q_{\text{inner-surface}} + Q_{\text{outer-surface}},$$

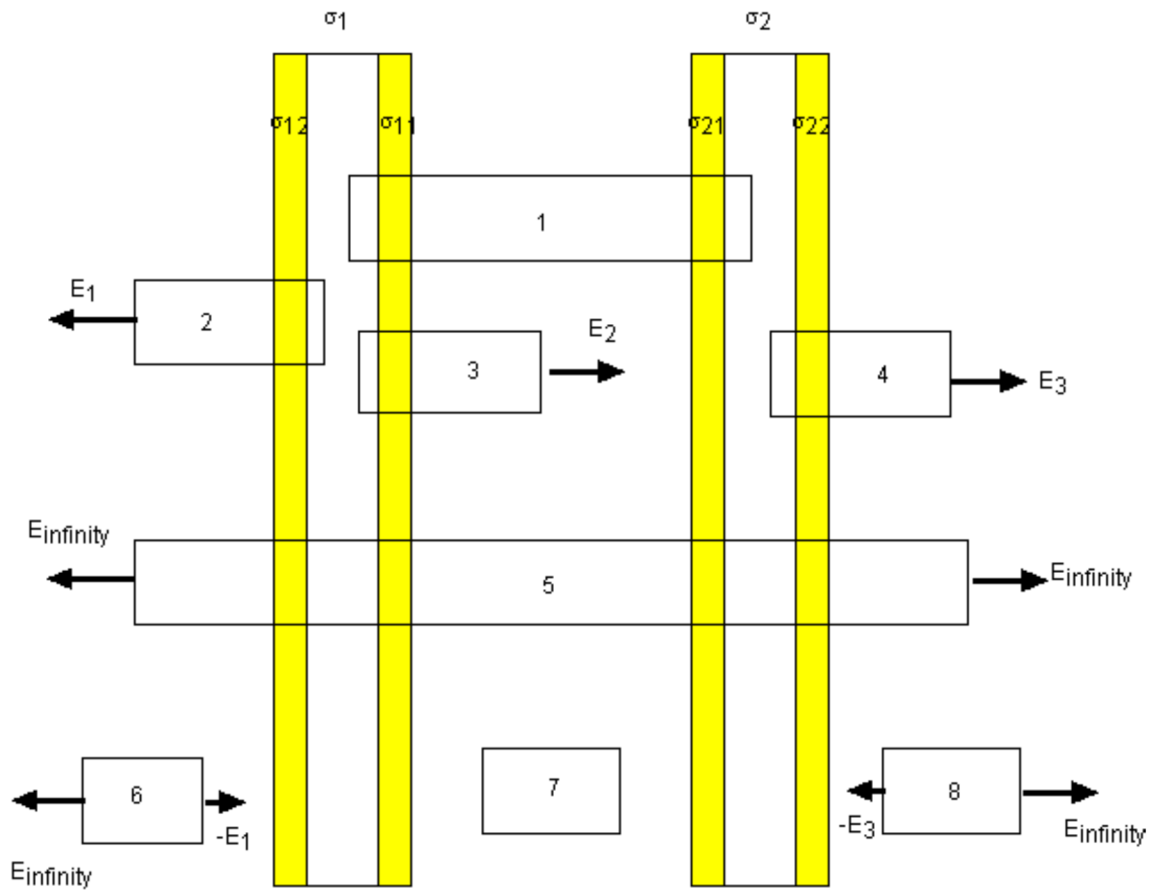
or

$$Q_{\text{outer-surface}} = Q_1 + Q_2.$$



### 8. Two parallel conducting plates with surface charge density ( $\sigma_1$ and $\sigma_2$ ).

We consider the two infinitely large conducting plates with the surface charge density ( $\sigma_1$  and  $\sigma_2$ ).



$$\begin{aligned}\sigma_1 &= \sigma_{11} + \sigma_{12} \\ \sigma_2 &= \sigma_{21} + \sigma_{22}\end{aligned}$$

From (1)

$$\sigma_{11} + \sigma_{21} = 0$$

From (2)

$$E_1 = \frac{\sigma_{12}}{\epsilon_0}$$

From (3)

$$E_2 = \frac{\sigma_{11}}{\epsilon_0}$$

From (4)

$$E_3 = \frac{\sigma_{22}}{\epsilon_0}$$

From (5)

$$E_{\text{infinity}} = \frac{\sigma_1 + \sigma_2}{2\epsilon_0}$$

From (6), (7), and (8), we have

$$E_{\text{infinity}} = E_1 = E_3$$

$$E_1 = \frac{\sigma_{12}}{\epsilon_0} = \frac{\sigma_{22}}{\epsilon_0}$$

or

$$\sigma_{12} - \sigma_{22} = 0$$

Then we have

$$\begin{pmatrix} 1 & 1 & 0 & 0 \\ 0 & 0 & 1 & 1 \\ 1 & 0 & 1 & 0 \\ 0 & 1 & 0 & -1 \end{pmatrix} \begin{pmatrix} \sigma_{11} \\ \sigma_{12} \\ \sigma_{21} \\ \sigma_{22} \end{pmatrix} = \begin{pmatrix} \sigma_1 \\ \sigma_2 \\ 0 \\ 0 \end{pmatrix}$$

Using Mathematica, we get

$$\sigma_{11} = \frac{\sigma_1 - \sigma_2}{2}$$

$$\sigma_{12} = \frac{\sigma_1 + \sigma_2}{2}$$

$$\sigma_{21} = \frac{-\sigma_1 + \sigma_2}{2}$$

$$\sigma_{22} = \frac{\sigma_1 + \sigma_2}{2}$$

The electric fields are given by

$$E_{\text{infinity}} = E_1 = E_3 = \frac{\sigma_1 + \sigma_2}{2\epsilon_0}$$

$$E_2 = \frac{\sigma_1 - \sigma_2}{2\epsilon_0}$$

((Mathematica))

```
M = {{1, 1, 0, 0}, {0, 0, 1, 1}, {1, 0, 1, 0},
      {0, 1, 0, -1}}; X = {x1, x2, x3, x4};
y = {σ1, σ2, 0, 0}; eq1 = M.X == y;
Solve[eq1, {x1, x2, x3, x4}]
{{x1 -> (σ1 - σ2)/2, x2 -> (σ1 + σ2)/2,
  x3 -> 1/2 (-σ1 + σ2), x4 -> (σ1 + σ2)/2}}
```

**9. Two parallel conducting plates with surface charge density ( $\sigma_1 = -\sigma_2 = \sigma$ ).**

We consider a typical case when  $\sigma_1 = \sigma$  and  $\sigma_2 = -\sigma$

$$\sigma_{11} = \frac{\sigma_1 - \sigma_2}{2} = \sigma$$

$$\sigma_{12} = \frac{\sigma_1 + \sigma_2}{2} = 0$$

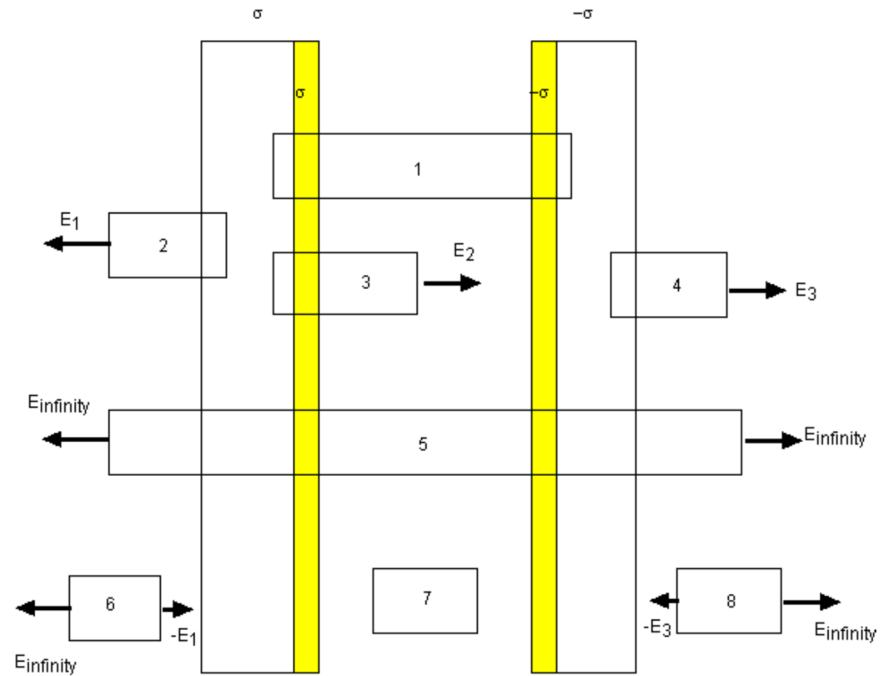
$$\sigma_{21} = \frac{-\sigma_1 + \sigma_2}{2} = -\sigma$$

$$\sigma_{22} = \frac{\sigma_1 + \sigma_2}{2} = 0$$

$$E_1 = E_3 = 0$$

$$E_2 = \frac{\sigma}{\epsilon_0}$$

Here we return to the original diagram



From (2),  $E_1 = 0$ .

From (3),  $E_2 = \frac{\sigma}{\epsilon_0}$

From (4),  $E_3 = 0$

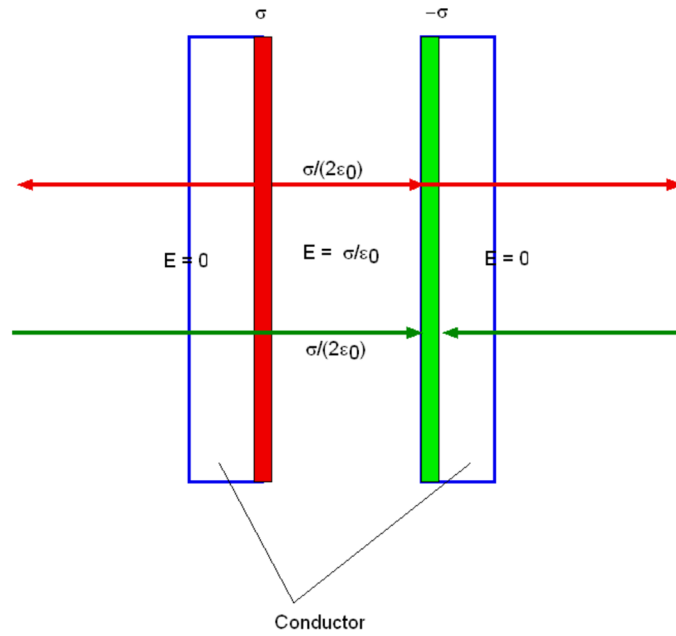
From (5),  $E_{\text{infinity}} = 0$ .

In conclusion, we have  $E = \frac{\sigma}{\epsilon_0}$  between two parallel conducting plates.

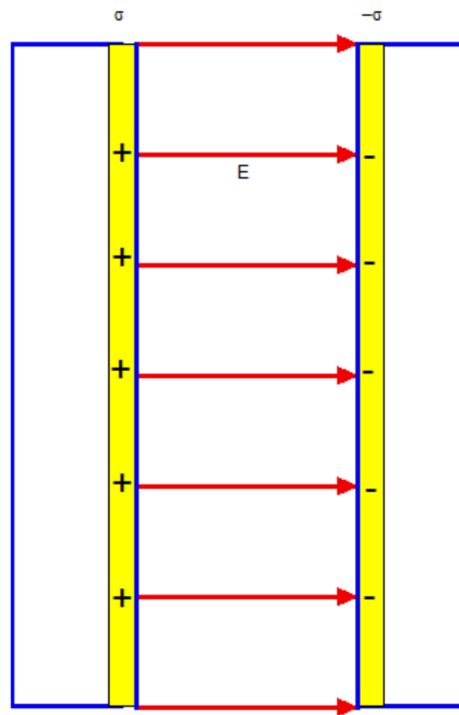
**((Another method))**

From the principle of the superposition we have only an electric field between the two plate of the capacitor;

$$E = \frac{\sigma}{\epsilon_0}.$$



which is equivalent to



**10. Electric field lines for the charges locating in the *one dimensional chain*.**

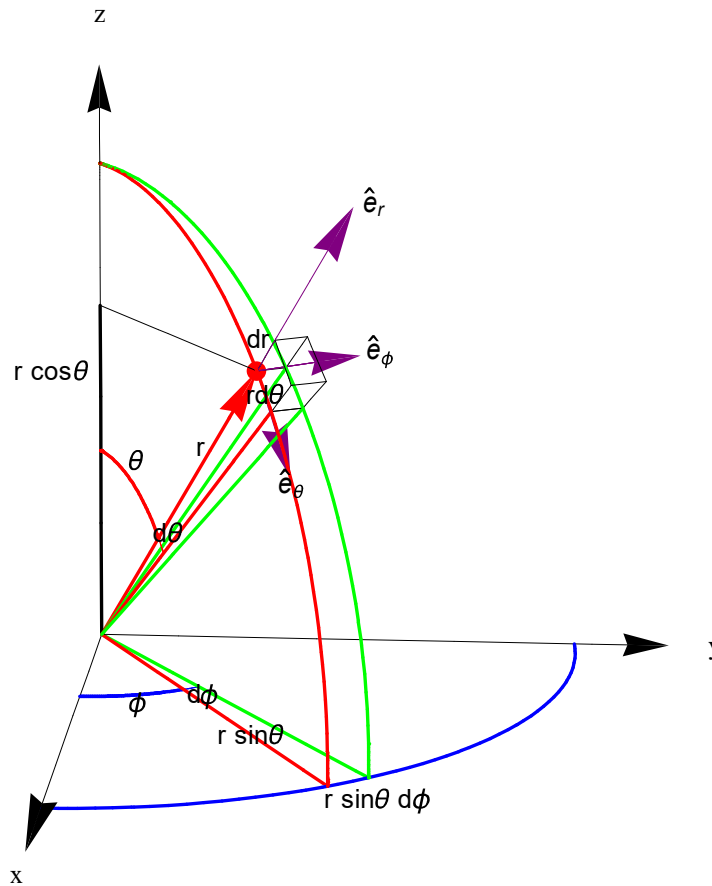
**10.1. Solid angle**

The solid angle  $\Omega$  subtended by a surface  $A$  is defined as the surface area  $\Omega$  of a unit sphere covered by the surface's projection onto the sphere. The solid angle of a cone with apex angle  $2\theta$ , is the area of a spherical cap on a unit sphere.

$$\begin{aligned} dA &= (rd\theta)(r \sin \theta)d\phi \\ &= \sin \theta d\theta d\phi \end{aligned}$$

where  $r = 1$ .

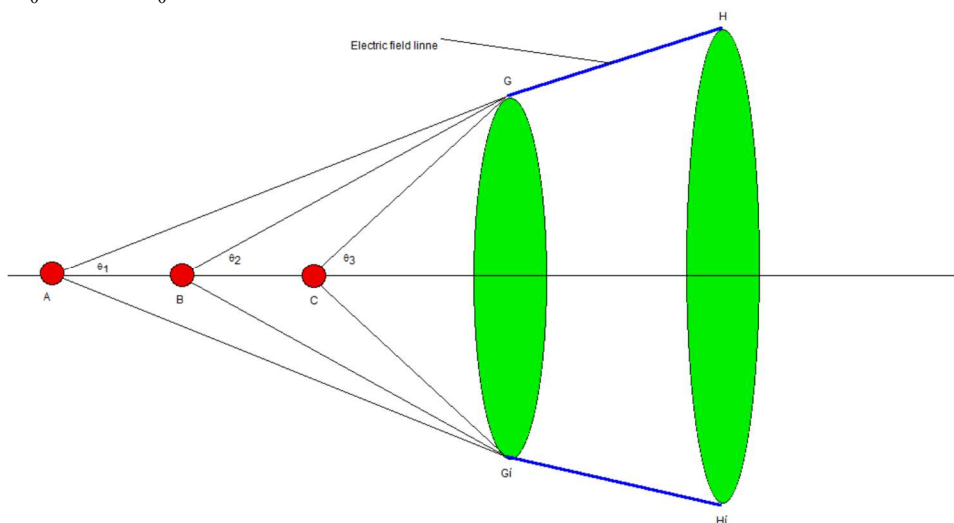
$$\begin{aligned} \Omega &= \int dA \\ &= \int_0^\theta \sin \theta d\theta \int_0^{2\pi} d\phi = 2\pi(1 - \cos \theta) \end{aligned}$$



## 10.2 The net flux of the electric field through a solid angle

We consider the flux of  $\mathbf{E}$  coming from a point charge  $q$ . The net flux of  $\mathbf{E}$ -lines passing through a solid angle  $\Omega$  is

$$\frac{q}{\epsilon_0} \frac{\Omega}{4\pi} = \frac{q}{2\epsilon_0} (1 - \cos \theta)$$



Suppose that the point charges ( $q_1, q_2, q_3, \dots$ ) are located in the one-dimensional line ( $x$  axis) (for example, the points A, B, C, ...). The points G and H are on the electric field line. The rotation of these two points G, H around the  $x$  axis leads to a disk GG', HH'. When the angles between one point on the electric field line and the point charges are given by  $\theta_1, \theta_2, \theta_3, \dots$ , the solid angles subtended by the disk GG' are  $\Omega_1, \Omega_2, \Omega_3, \dots$ . The net flux of  $E$ -lines passing through the disk GG' is

$$\sum_i \frac{q_i}{2\epsilon_0} (1 - \cos \theta_i).$$

If the line GH is the electric field line, the total number of  $E$ -lines passing through the disk GG' is equal to that through HH'. Thus we reach a conclusion that

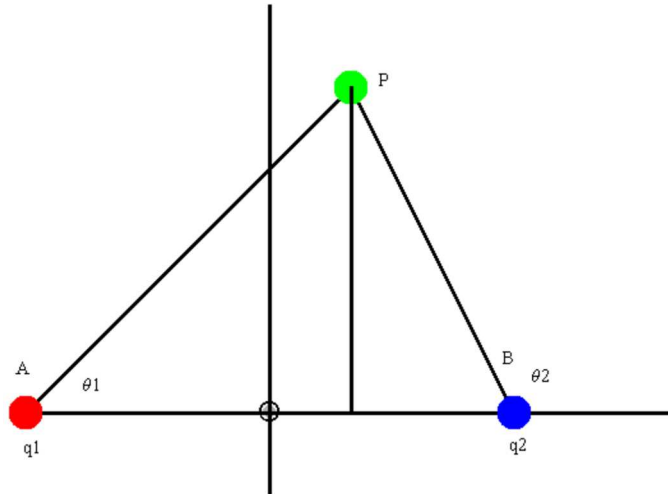
$$\sum_i \frac{q_i}{2\epsilon_0} (1 - \cos \theta_i) = \text{const},$$

or

$$\sum_i q_i \cos \theta_i = \text{const}.$$

We consider the case of two charges located on the different places along the  $x$  axis.





Suppose that the point charge ( $q_1$ ) and the point charge ( $q_2$ ) are located at the points A ( $x_1,0$ ) and the point ( $x_2,0$ ).

$$\cos \theta_1 = \frac{x - x_1}{\sqrt{(x - x_1)^2 + y^2}}$$

$$\cos \theta_2 = \frac{x - x_2}{\sqrt{(x - x_2)^2 + y^2}}$$

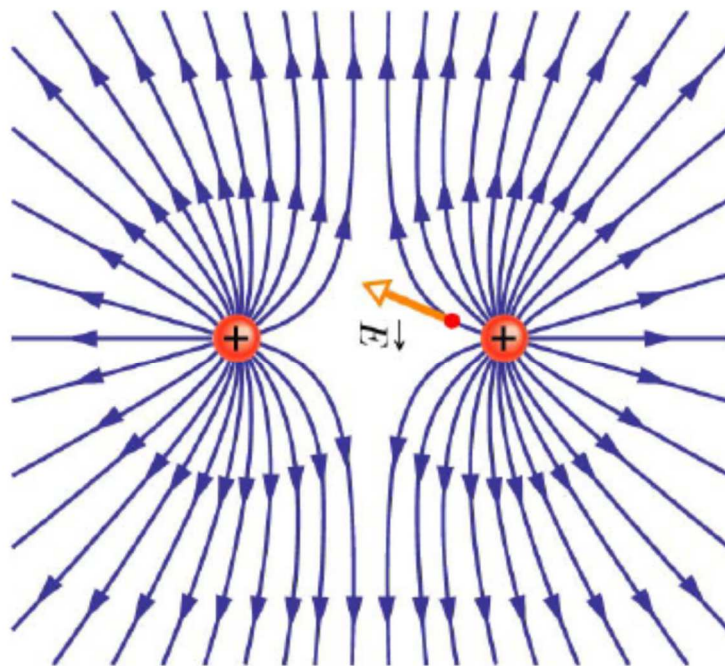
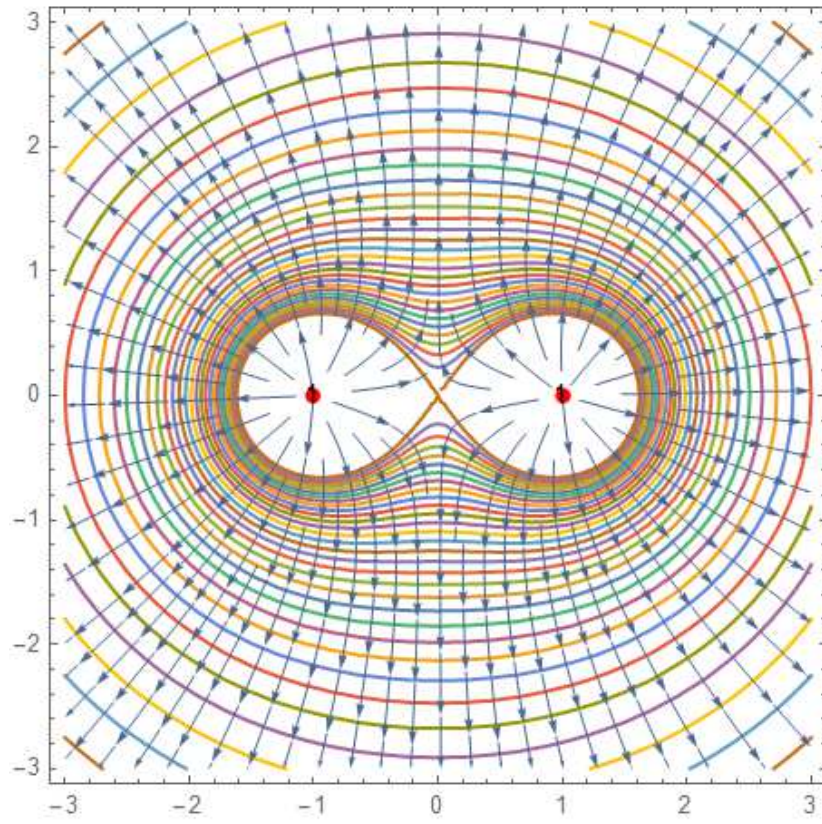
The electric lines are described by

$$q_1 \cos \theta_1 + q_2 \cos \theta_2 = \frac{q_1(x - x_1)}{\sqrt{(x - x_1)^2 + y^2}} + \frac{q_2(x - x_2)}{\sqrt{(x - x_2)^2 + y^2}} = \text{constant}$$

### 10.3 Examples

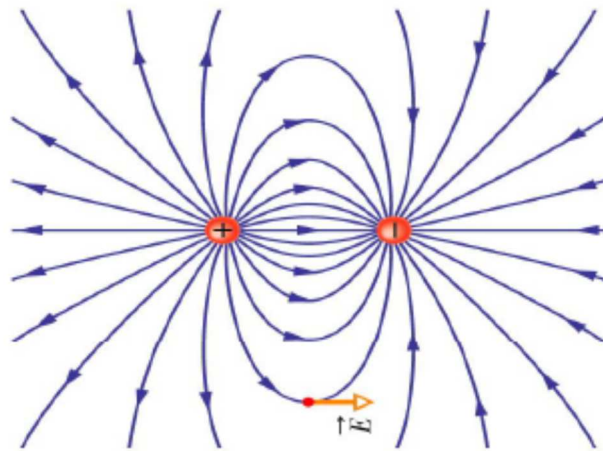
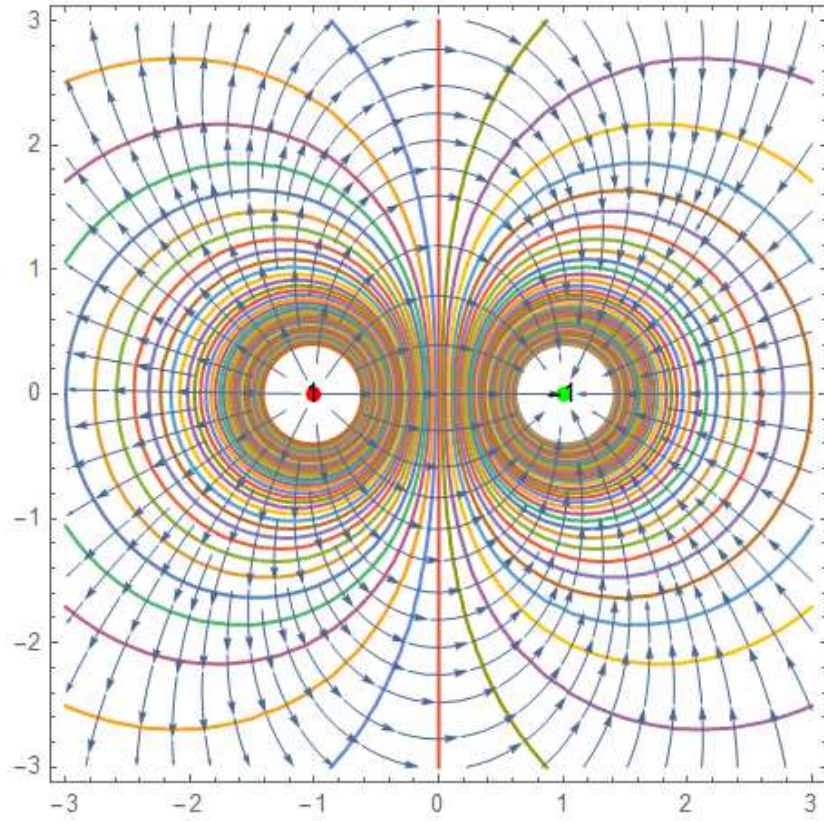
((Example-1))

$q$  at  $(-1,0)$   
 $q$  at  $(1,0)$



**((Example-2))**

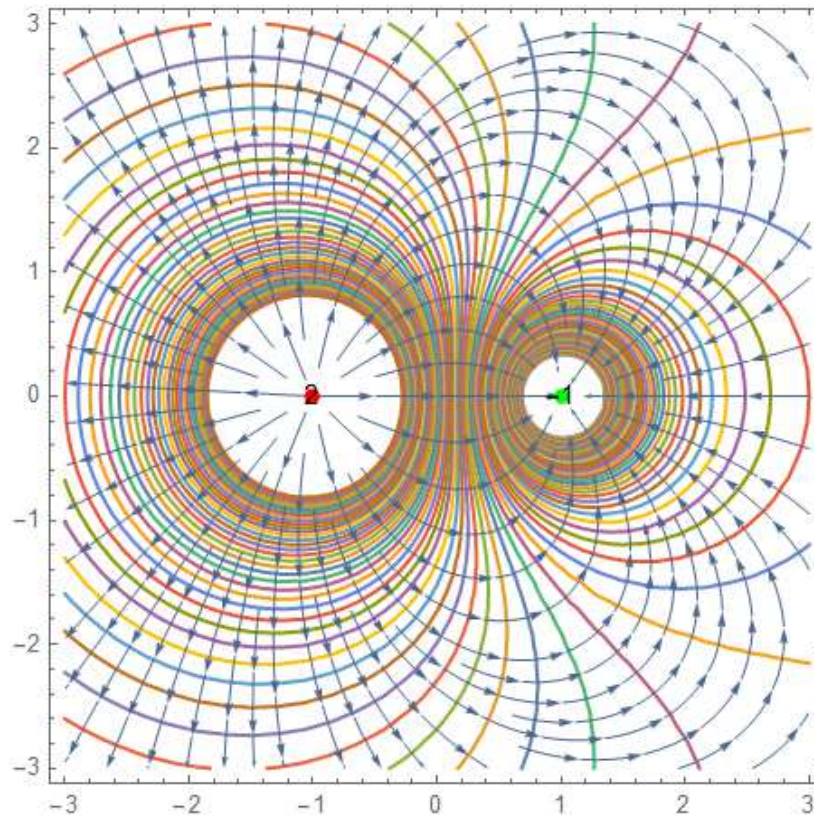
$q$  at  $(-1,0)$   
 $-q$  at  $(1,0)$





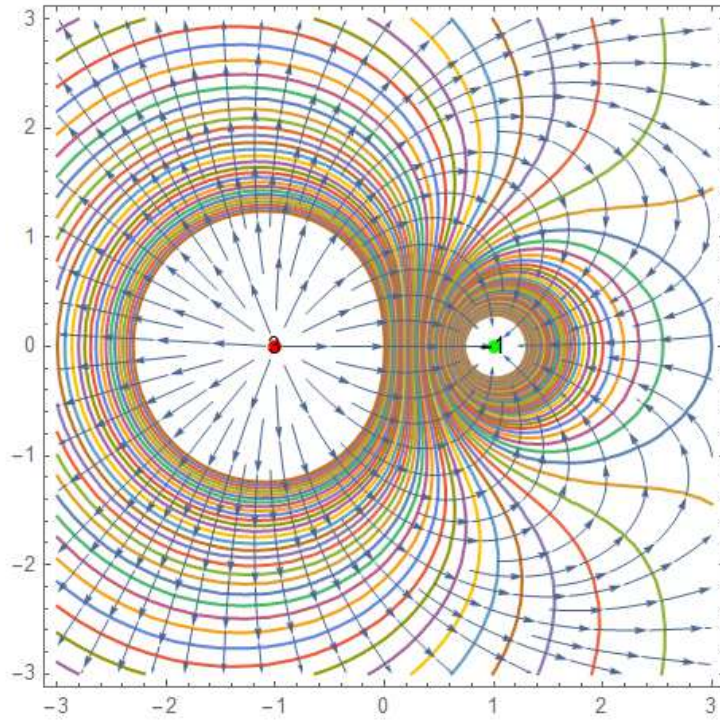
**((Example-3))**

$2q$  at  $(-1,0)$   
 $-q$  at  $(1,0)$



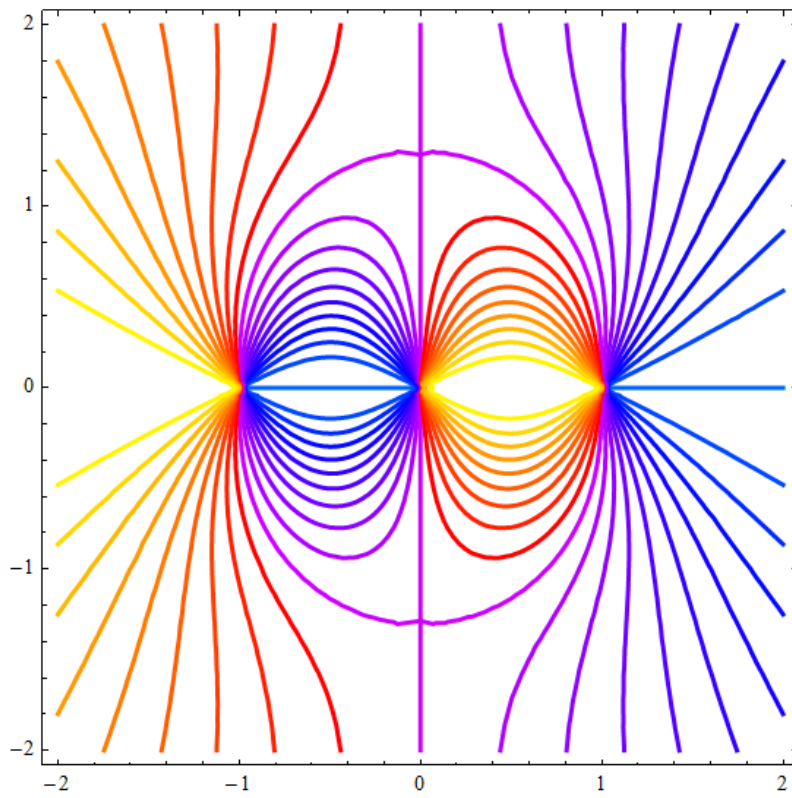
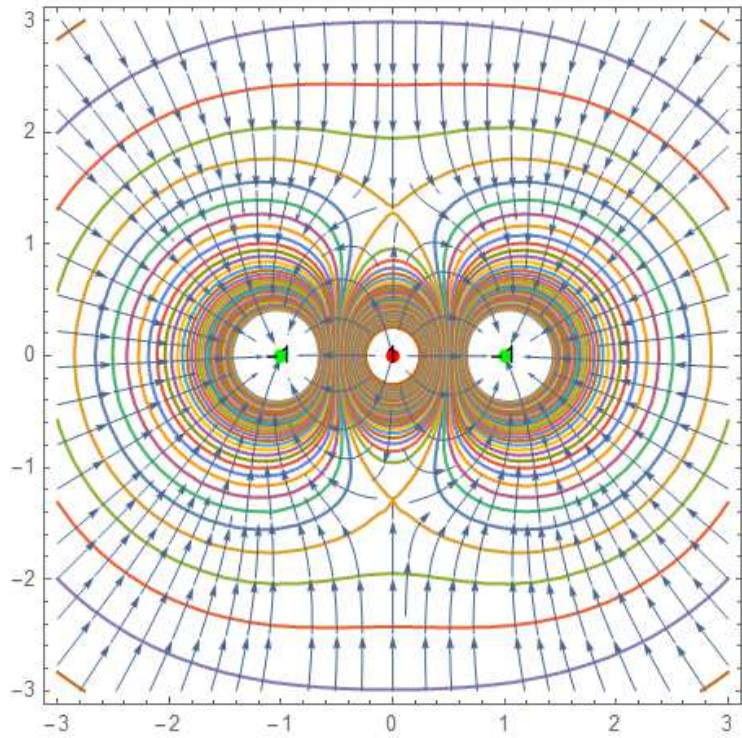
**((Example-4))**

$3q$  at  $(-1,0)$   
 $-q$  at  $(3,0)$



**((Example-5))**

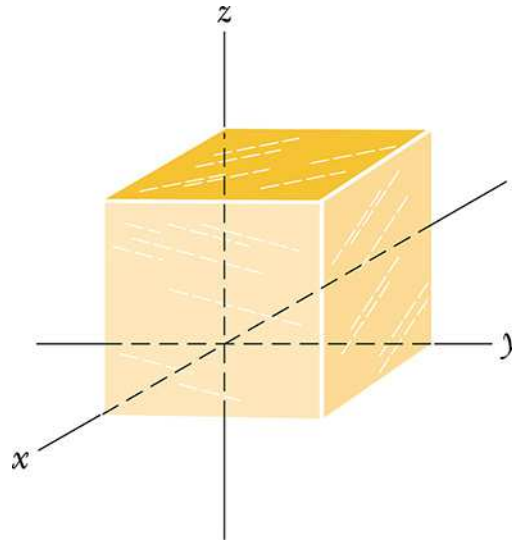
$-q$  at  $(-1,0)$ ,  $q$  at  $(0, 0)$  and  
 $-q$  at  $(1,0)$



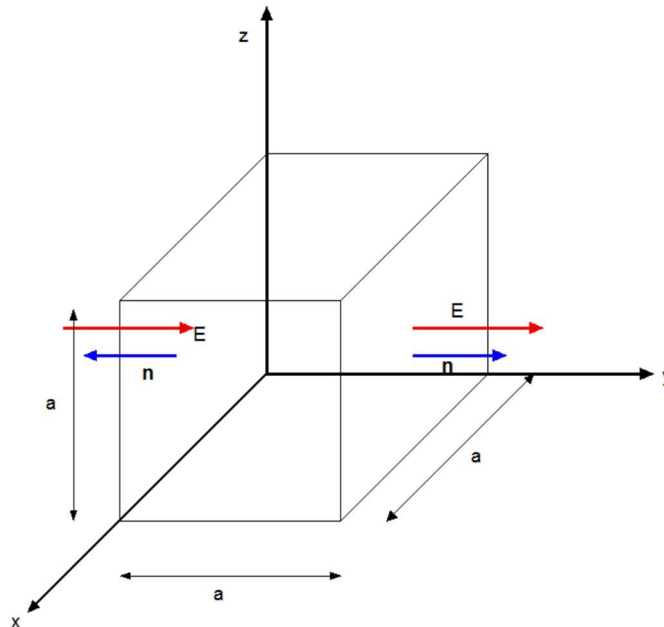
**11. Typical examples**

### 11.1 Problem 23-11 (SP-23)

Figure shows a Gaussian surface in the shape of a cube with edge length 1.40 m. What are (a) the net flux  $\Phi$  through the surface and (b) the net charge  $q_{\text{enc}}$  enclosed by the surface if  $\mathbf{E} = (3.00 y \mathbf{e}_y) \text{ N/C}$ , with  $y$  in meters? What are (c) the net flux  $\Phi$  through the surface and (d) the net charge  $q_{\text{enc}}$  enclosed by the surface if  $\mathbf{E} = [-4.00 \mathbf{e}_x + (6.00 + 3.00 y) \mathbf{e}_y] \text{ N/C}$ , with  $y$  in meters?



((Solution))



$$a = 1.4 \text{ m}$$

(a) and (b)

$$\mathbf{E} = 3.0 y \mathbf{e}_y \text{ N/C}$$

The electric flux,

$$\Phi = \oint \mathbf{E} \cdot d\mathbf{a} = (3.0 \cdot a)a^2 - (3.0 \cdot 0)a^2 = 3a^3 = \frac{Q_{net}}{\epsilon_0}$$

or

$$\begin{aligned}\Phi &= 3a^3 = 8.23 \text{ N} \cdot \text{m}^2 / \text{C} \\ Q_{net} &= \epsilon_0(3a^3) = 7.29 \times 10^{-11} \text{ C}\end{aligned}$$

(c) and (d)

$$\mathbf{E} = [-4 \mathbf{e}_x + (6 + 3y)\mathbf{e}_y] \text{ N/C}$$

$$\Phi = \frac{Q_{net}}{\epsilon_0} = \oint \mathbf{E} \cdot d\mathbf{a} = (6 + 3.0 \cdot a)a^2 - (6 + 3.0 \cdot 0)a^2 = 3a^3$$

Then we have

$$\begin{aligned}\Phi &= 3a^3 = 8.23 \text{ N} \cdot \text{m}^2 / \text{C} \\ Q_{net} &= \epsilon_0(3a^3) = 7.29 \times 10^{-11} \text{ C}\end{aligned}$$

where  $\epsilon_0 = 8.854187817 \times 10^{-12} \text{ (F/m)}$

**((Another method))** We use the Gauss' law;  $\oint \mathbf{E} \cdot d\mathbf{a} = \int (\nabla \cdot \mathbf{E})d\tau$

(a) and (b)

$$\mathbf{E} = 3.0y \mathbf{e}_y \text{ N/C}$$

$$\oint \mathbf{E} \cdot d\mathbf{a} = \int (\nabla \cdot \mathbf{E})d\tau = 3 \int d\tau = 3a^3$$

since

$$\nabla \cdot \mathbf{E} = \frac{\partial E_x}{\partial x} + \frac{\partial E_y}{\partial y} + \frac{\partial E_z}{\partial z} = 3$$

(c) and (d)

$$\mathbf{E} = [-4 \mathbf{e}_x + (6 + 3y)\mathbf{e}_y] \text{ N/C}$$



$$\oint \mathbf{E} \cdot d\mathbf{a} = \int (\nabla \cdot \mathbf{E}) d\tau = 3 \int d\tau = 3a^3$$

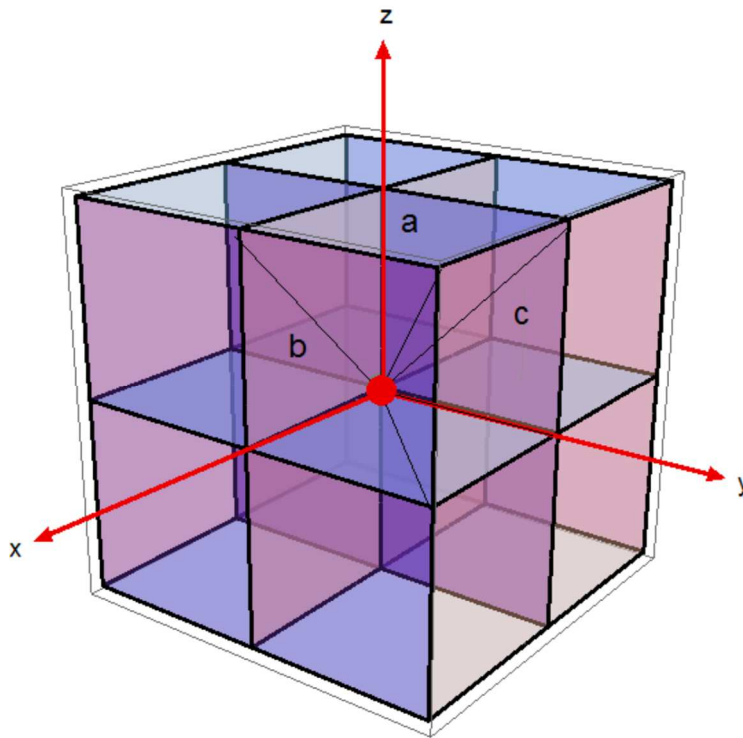
since

$$\nabla \cdot \mathbf{E} = \frac{\partial E_x}{\partial x} + \frac{\partial E_y}{\partial y} + \frac{\partial E_z}{\partial z} = 3$$

### 11.2 Problem 23-13 (SP-23)

A particle of charge  $+q$  is placed at one corner of a Gaussian cube. What multiple of  $q/\epsilon_0$  gives the flux through (a) each cube face forming that corner and (b) each of the other cube faces.

((Solution))



(a)

$$\Phi_{total} = \oint \mathbf{E} \cdot d\mathbf{a} = \frac{q}{\epsilon_0}$$

There are 8 cubes around the origin. Then we have

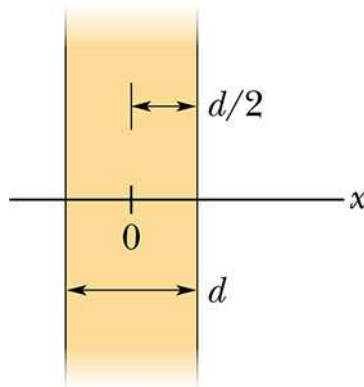
$$\Phi = \frac{1}{8} \Phi_{total} = \frac{q}{8\epsilon_0}$$

(b) The flux passing through  $a$ ,  $b$ , and  $c$ -faces is the same from the symmetry. The flux passing through the other faces is zero, since  $E$  is perpendicular to the normal direction of the faces. Then we have

$$\Phi_a = \frac{1}{3} \frac{q}{8\epsilon_0} = \frac{q}{24\epsilon_0}$$

### 11.3 Problem 23-43 (SP-23)

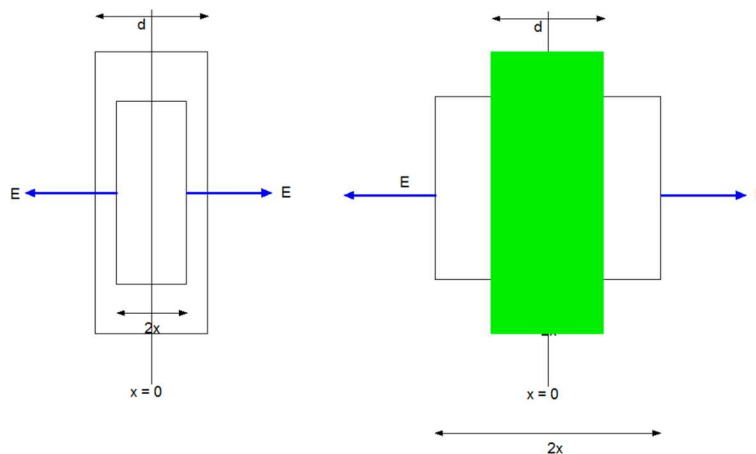
Figure shows a cross section through a very large non-conducting slab of thickness  $d = 9.40$  mm and uniform volume charge density  $\rho = 5.80 \mu\text{C}/\text{m}^3$ . The origin of an  $x$  axis is at the slab's center. What is the magnitude of the slab's electric field at an  $x$  coordinate of (a) 0, (b) 2.00 mm, (c) 4.70 mm, and (d) 26.00 mm?



**((Solution))**

$$\rho = 5.80 \mu\text{C}/\text{m}^3$$

$$d = 9.40 \text{ mm}$$



For  $0 < x < d/2$

For  $x > d/2$

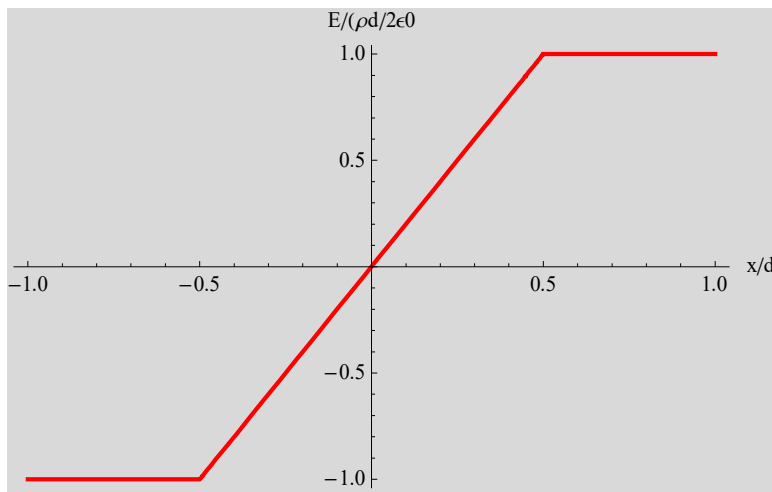
$$2E\Delta a = \frac{1}{\epsilon_0}(2x)\Delta a\rho$$

$$E = \frac{\rho x}{\epsilon_0}$$

$$2E\Delta a = \frac{1}{\epsilon_0}d\Delta a\rho$$

$$E = \frac{\rho d}{2\epsilon_0}$$

$x = 0$	$E = 0$
$x = 2.0 \text{ mm}$	$E = 1.31 \times 10^{-6} \text{ N/C}$
$x = 4.7 \text{ mm}$	$E = 3.08 \times 10^{-6} \text{ N/C}$
$x = 26.0 \text{ mm}$	$E = 3.08 \times 10^{-6} \text{ N/C}$



#### 11.4 Problem 23-55 (SP-23)

A solid nonconducting sphere of radius  $R = 5.60 \text{ cm}$  has a non-uniform charge distribution of volume charge density  $\rho = (141 \text{ pC/m}^3) r/R$ , where  $r$  is radial distance from the sphere's center. (a) What is the sphere's total charge? What is the magnitude  $E$  of the electric field at (b)  $r = 0$ , (c)  $r = R/2.00$ , and (d)  $r = R$ ? (e) Sketch a graph of  $E$  vs  $t$ .

**((Solution))**

$$R = 5.60 \text{ cm}$$

$$\rho = \frac{Ar}{R} \quad \text{with } A = 14.1 \text{ pC/m}^3.$$

(a)

$$\begin{aligned} Q &= \int_0^R 4\pi r^2 \rho(r) dr = \int_0^R 4\pi r^2 \frac{Ar}{R} dr \\ &= \frac{4\pi A}{R} \int_0^R r^3 dr = \pi A R^3 = 7.79 \times 10^{-15} \text{ C} \end{aligned}$$

(b)

For  $r > R$

$$E = \frac{1}{4\pi\epsilon_0} \frac{Q}{r^2} = \frac{AR^3}{4\epsilon_0 r^2} = \frac{AR}{4\epsilon_0} \left(\frac{R}{r}\right)^2$$

Here we put  $E_0 = \frac{AR}{4\epsilon_0}$ .

$$\frac{E}{E_0} = \frac{1}{\xi^2} \quad (\xi > 1)$$

with  $\xi = \frac{r}{R}$

For  $r < R$

$$\begin{aligned} 4\pi r^2 E &= \frac{1}{\epsilon_0} \int_0^r 4\pi r'^2 \rho(r') dr' \\ &= \frac{\pi A}{\epsilon_0 R} r^4 \end{aligned}$$

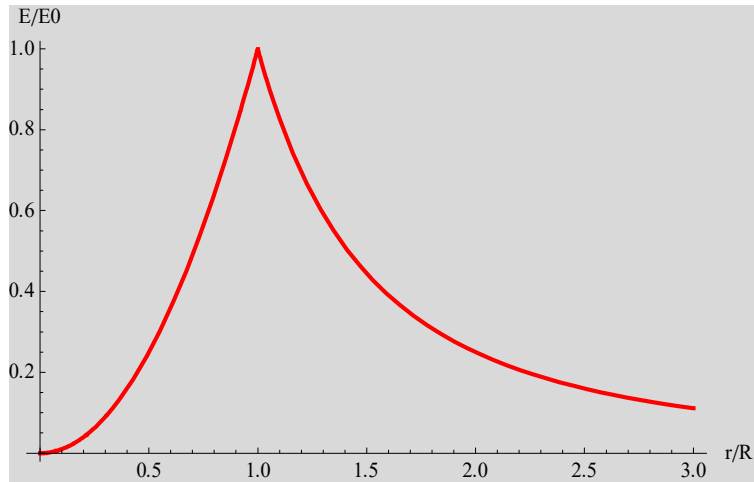
or

$$E = \frac{A}{4\epsilon_0 R} r^2 = \frac{AR}{4\epsilon_0} \left(\frac{r}{R}\right)^2 = E_0 \left(\frac{r}{R}\right)^2$$

This can be rewritten as

$$\frac{E}{E_0} = \xi^2 \quad (\xi < 1)$$

- (a) At  $r = 0$ ,  $E = 0$   
(b) At  $r/R = 0.5$ ,  $E = 5.57 \times 10^{-3}$  N/C  
(c) At  $r/R = 1$ ,  $E = 2.23 \times 10^{-2}$  N/C

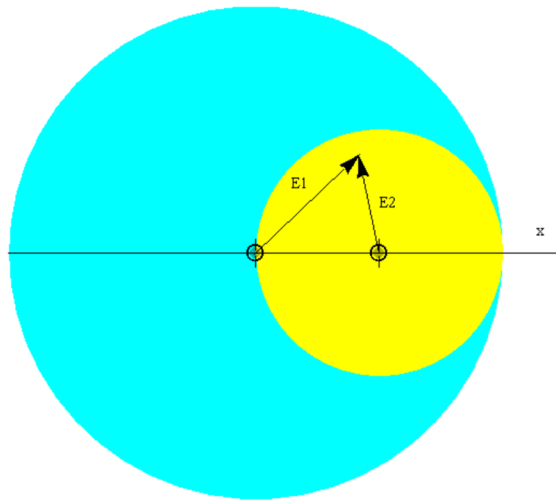


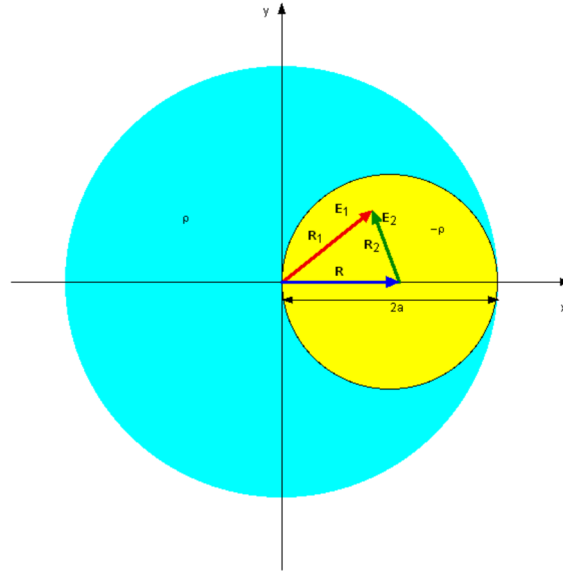
## 12. Advanced problem

### 12.1 AP-1

A sphere of radius  $2a$  is made of a nonconducting material that has a uniform volume charge density  $\rho$ . (Assume that the material does not affect the electric field.) A spherical cavity of radius  $a$  is now removed from the sphere. Show that the electric field within the cavity is uniform and is given by  $E_x = 0$  and  $E_y = \rho a / (3\epsilon_0)$ .

**((Solution))**





The electric field  $E_1$  due to the sphere (radius  $2a$ , uniform charge density  $\rho$ ) is given by

$$E_1 = \frac{\rho R_1}{3\epsilon_0}$$

The electric field  $E_2$  due to the sphere (radius  $a$ , uniform charge density  $-\rho$ ) is given by

$$E_2 = -\frac{\rho R_2}{3\epsilon_0}$$

From the superposition principle, the resultant electric field  $E$  is given by

$$E = E_1 + E_2 = \frac{\rho}{3\epsilon_0}(R_1 - R_2) = \frac{\rho}{3\epsilon_0} R$$

## 12.2 AP-2

Charge is distributed throughout a sphere of radius  $R$  with density  $\rho(r) = \rho_0/r$ . Find  $E$  everywhere. Express the field outside the sphere in terms of the total charge  $Q$  in the sphere.

**((Solution))**

We apply the Gauss' law.

For  $r < R$ , the Gaussian sphere is a sphere with a radius  $r$ .

$$\oint E \cdot dA = 4\pi r^2 E$$

$$= \frac{1}{\epsilon_0} \int_0^r \rho(r) 4\pi r^2 dr$$

$$= \frac{1}{\epsilon_0} \int_0^r \frac{\rho_0}{r} 4\pi r^2 dr = \frac{4\pi\rho_0}{\epsilon_0} \int_0^r r dr = \frac{4\pi\rho_0}{\epsilon_0} \frac{r^2}{2} = \frac{2\pi\rho_0}{\epsilon_0} r^2$$

or

$$4\pi r^2 E = \frac{2\pi\rho_0}{\epsilon_0} r^2 \quad \text{or} \quad E = \frac{\rho_0}{2\epsilon_0} = \frac{Q}{2\pi R^2} \frac{1}{2\epsilon_0} = \frac{Q}{4\pi\epsilon_0 R^2} \quad (r < R)$$

Here we note that the total charge  $Q$  is given by

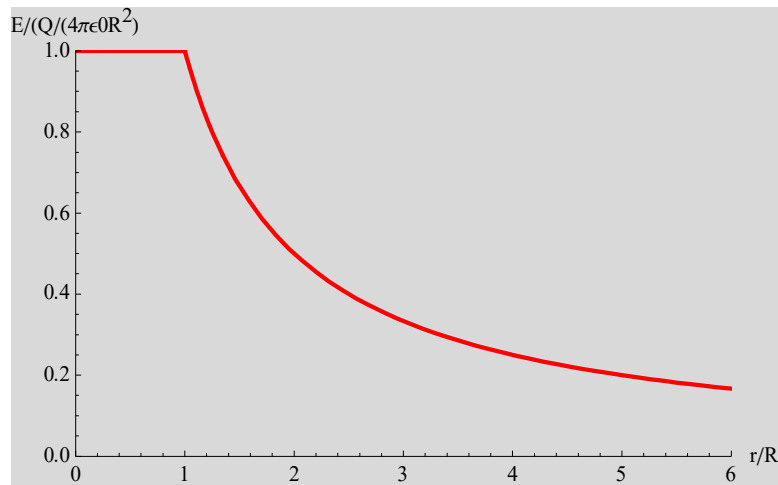
$$Q = \int_0^R \rho(r) 4\pi r^2 dr = 4\pi\rho_0 \int_0^R \frac{1}{r} r^2 dr = 4\pi\rho_0 \int_0^R r dr = 4\pi\rho_0 \frac{R^2}{2} = 2\pi\rho_0 R^2$$

For  $r > R$ ,

$$\oint E \cdot dA = 4\pi r^2 E = \frac{1}{\epsilon_0} Q$$

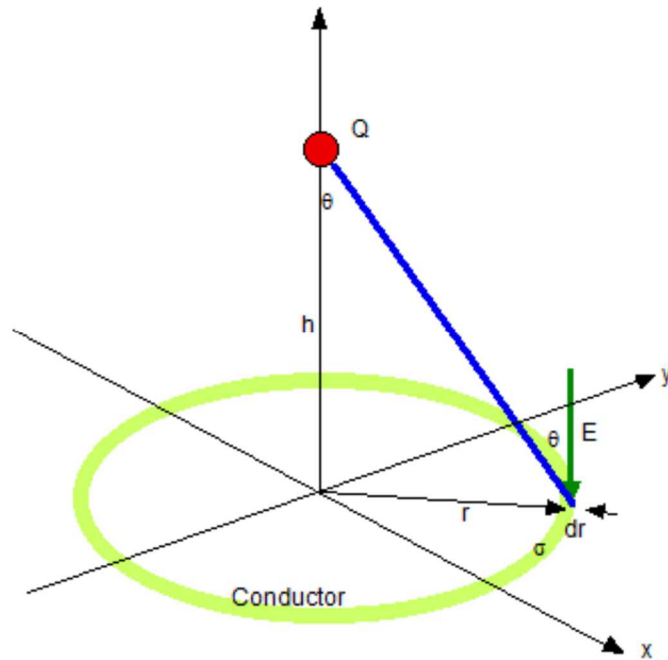
or

$$E = \frac{Q}{4\pi\epsilon_0 r^2} \quad (r > R)$$



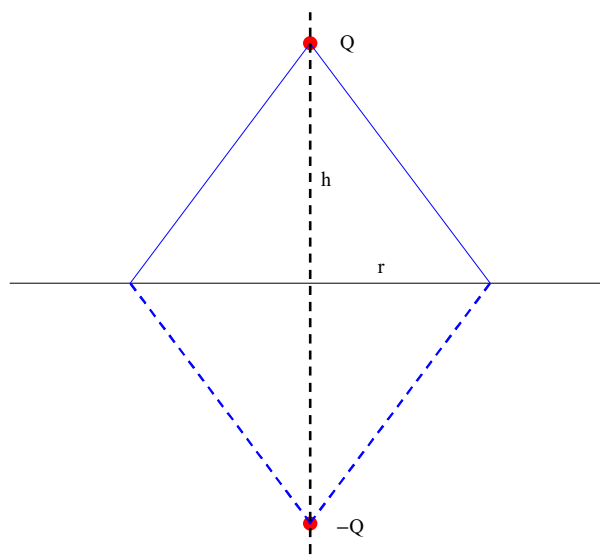
### 12.3 AP-3

We now consider a simple system where a positive point charge is located ( $h$ ) above an infinite plane conductor. Suppose that  $xy$  plane is the surface of a conductor. What sort of the electric field and charge distribution can we expect?

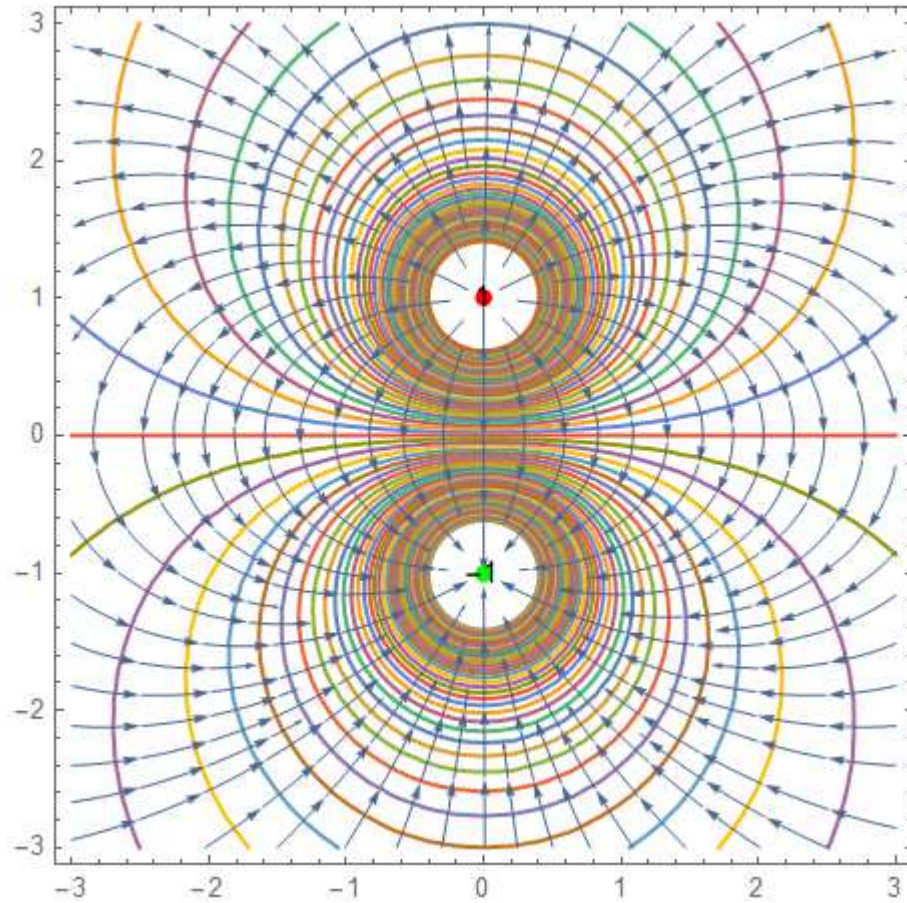


The electric field is always perpendicular to the surface of a conductor, at the conductor's surface. Very near the point charge  $Q$ , on the other hand, the presence of the conducting plane can make little difference. The electric field line must start out from  $Q$  as if they were leaving a point charge radially. (Purcell E&M).

How do we really solve the problem? The answer is, by a trick, but a trick that is both instructive and frequently useful. We find an easily soluble problem whose solution, or piece of it, can be made to fit the problem at hand. Here the easy problem is that of two equal and opposite point charges,  $Q$  and  $-Q$  in the plane which bisects the line joining the two charges.







The electric field along the  $z$  axis in the  $x y$  plane is given by

$$E_z = -2 \frac{Q}{4\pi\epsilon_0} \frac{1}{(r^2 + h^2)} \cos\theta = -2 \frac{Q}{4\pi\epsilon_0} \frac{1}{(r^2 + h^2)} \frac{h}{(r^2 + h^2)^{1/2}}$$

$$= -\frac{Q}{2\pi\epsilon_0} \frac{h}{(r^2 + h^2)^{3/2}}$$

The surface charge density  $\sigma$  is given by

$$\sigma = \epsilon_0 E_z = -\frac{Q}{2\pi} \frac{h}{(r^2 + h^2)^{3/2}}$$

The total surface charge is calculated as

$$\int_0^{\infty} \sigma(2\pi r) dr = -\frac{Qh}{2\pi} \int_0^{\infty} \frac{2\pi r}{(r^2 + h^2)^{3/2}} dr$$

$$= -Qh \int_0^{\infty} \frac{r}{(r^2 + h^2)^{3/2}} dr = -Q$$

It means that all the flux leaving the charge  $Q$  ends on the conducting plane.

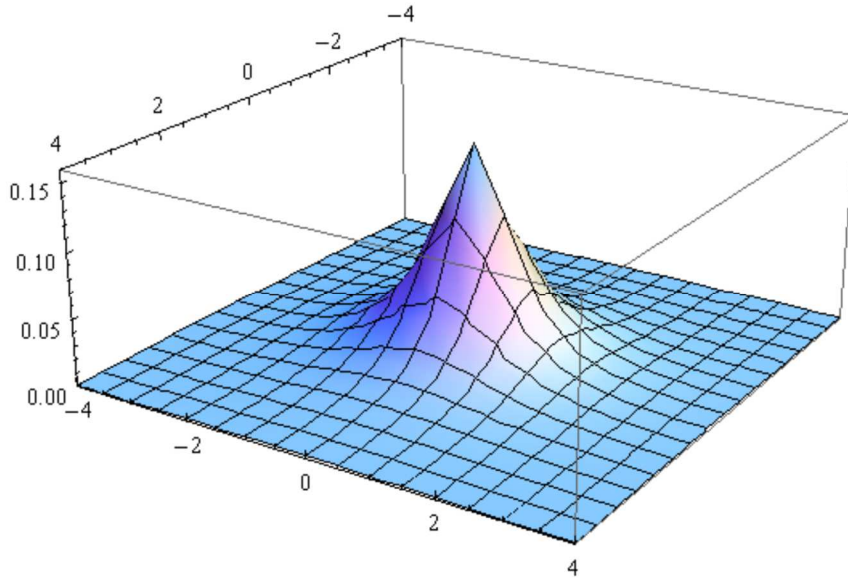
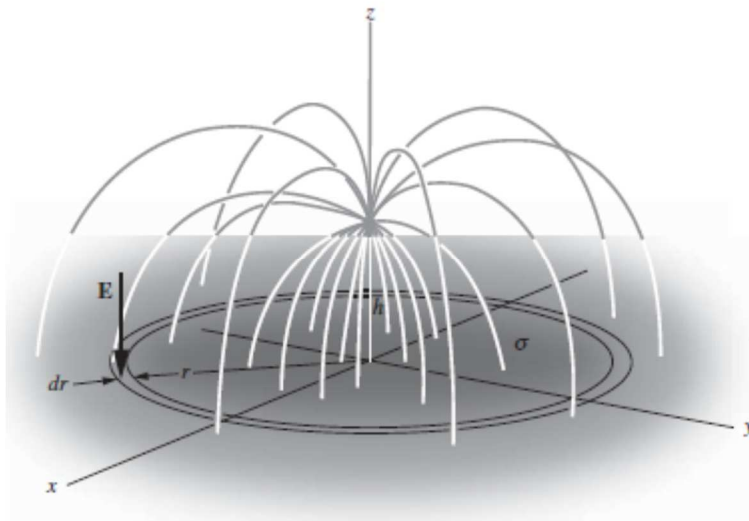


Fig. The Plot3D of the minus of the surface charge density with  $h = 1$  and  $Q = 1$ .

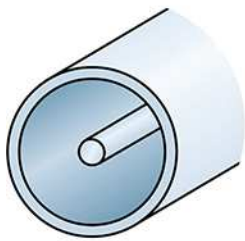


**Fig.** From E.M. Purcell and D.J. Morin, *Electricity and Magnetism*, 3<sup>rd</sup> edition (Cambridge, 2013). Fig.3.11 p.138.

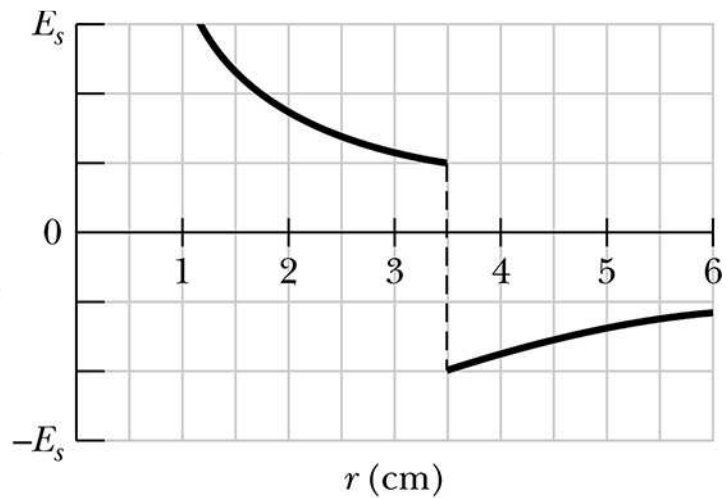
**13. Hint of HW-23**

**13.1 Problem 23-28 (HW-23)**

Figure (a) shows a narrow charged solid cylinder that is coaxial with a larger charged cylindrical shell. Both are nonconducting and thin and have uniform surface charge densities on their outer surfaces. Figure (b) gives the radial component  $E$  of the electric field versus radial distance  $r$  from the common axis. The vertical scale is set by  $E_s = 3.0 \times 10^3 \text{ N/C}$ . What is the linear charge density of the shell?



(a)



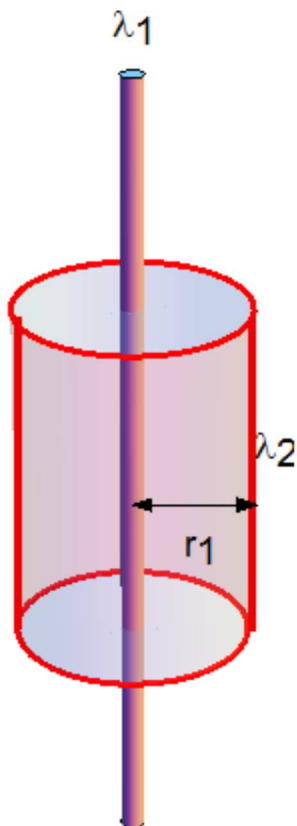
(b)

**((Solution))**

$$r_1 = 3.5 \text{ cm}$$

$$E_1 = 1 \times 10^3 \text{ N/C}$$

$$E_2 = -2 \times 10^3 \text{ N/C}$$



For  $r < r_1$ ,

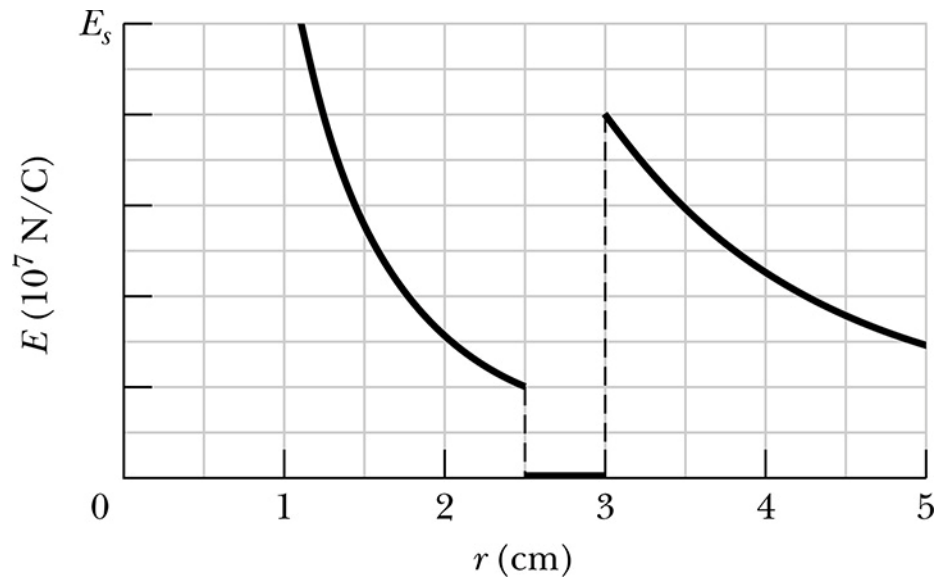
Gauss's law

$$E_1(2\pi r h) = \frac{1}{\epsilon_0}(\lambda_1 h)$$

$$E_1 = \frac{\lambda_1}{2\pi\epsilon_0 r}$$

### 13.2 Problem 23-52

A charged particle is held at the center of a spherical shell. Figure gives the magnitude  $E$  of the electric field versus radial distance  $r$ . The scale of the vertical axis is set by  $E_s = 10.0 \times 10^7$  N/C. Approximately, what is the net charge on the shell?



((My solution))

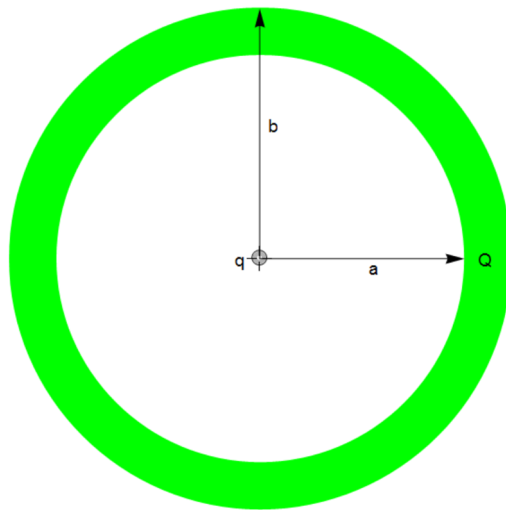
$$a = 2.5 \text{ cm}$$

$$b = 3.0 \text{ cm}$$

$$E(a) = 0.2 E_s$$

$$E(b) = 0.8 E_s$$

$$E_s = 10.0 \times 10^7 \text{ N/C}$$



Inside the shell ( $r < a$ )

$$E = \frac{q}{4\pi\epsilon_0 r^2}$$

#### REFERENCES

E.M. Purcell and D.J. Morin, Electricity and Magnetism, 3<sup>rd</sup> edition (Cambridge University Press).

R.P. Feynman, R.B. Leighton, and M. Sands, The Feynman Lectures on Physics (Addison-Wesley, 1964).

D.J. Griffiths Introduction to Electrodynamics, 4<sup>th</sup> edition (Pearson, 2013).

J.R. Reitz, F.J. Milford, and R.W. Christy, Fundamentals of Electromagnetic Theory, 3<sup>rd</sup> edition (Addison-Wesley, 1980).

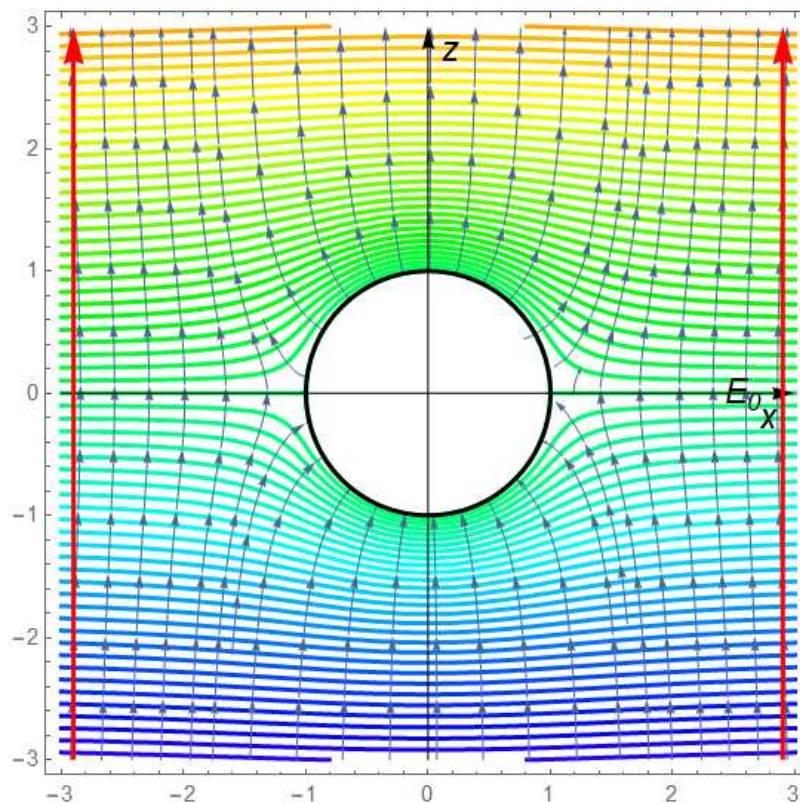
## APPENDIX

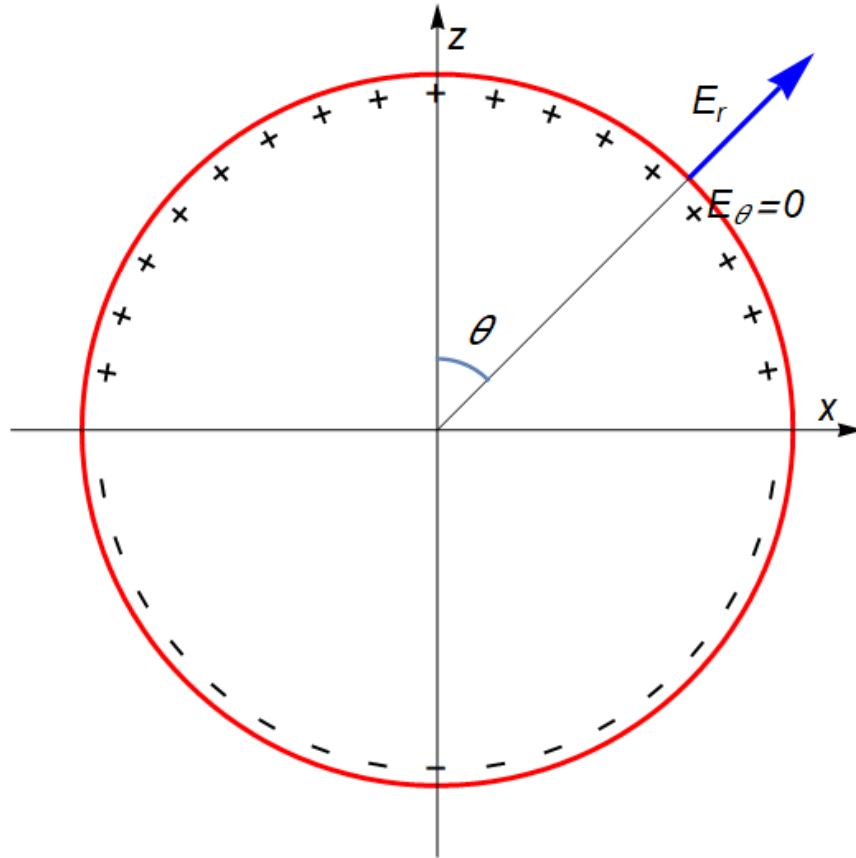
### ((Example)) Solution of Laplace's equation with a boundary condition

**D.J. Griffiths, Introduction to Electrodynamics, 4<sup>th</sup> edition (Pearson, 2013).**

**Example-8, p.141**

An uncharged metal sphere of radius  $R$  is placed in an otherwise uniform electric field  $E_0 e_z$ . The field will push positive charge to the northern surface of the sphere, leaving a negative charge on the southern surface. This induced charge, in turn, distort the field in the neighborhood of the sphere. Find the potential in the region outside the sphere.





The sphere is an equipotential – we may as well set it to zero. Then by symmetry the entire  $xy$  plane is at potential zero. This time, however,  $V$  does not go to zero at large  $z$ . In fact, far from the sphere the field is  $E_0 \mathbf{e}_z$ , and hence

$$V \rightarrow -E_0 z + C$$

Since  $V = 0$ , in the equatorial plane, the constant  $C$  must be zero. Accordingly, the boundary conditions for this problem are

- (i)  $V = 0$  at  $r = R$
- (ii)  $V = -E_0 r \cos \theta$  for  $r \gg R$

We must fit these boundary conditions with a function of the form,

$$V(r, \theta) = \sum_{l=0}^{\infty} \left( A_l r^l + \frac{B_l}{r^{l+1}} \right) P_l(\cos \theta)$$

which is the general solution of the Laplace's equation;  $\nabla^2 V = 0$ . The first condition yields

$$A_l R^l + \frac{B_l}{R^{l+1}} = 0$$

or

$$B_l = -A_l R^{2l+1}$$

So

$$V(r, \theta) = \sum_{l=0}^{\infty} A_l \left( r^l - \frac{R^{2l+1}}{r^{l+1}} \right) P_l(\cos \theta)$$

For  $r \gg R$ , the second term in parentheses is negligible, and therefore condition (ii) requires that

$$\sum_{l=0}^{\infty} A_l r^l P_l(\cos \theta) = -E_0 r \cos \theta$$

Evidently only one term is present:  $l = 1$ . In fact, since  $P_1(\cos \theta) = \cos \theta$ , we can read off immediately

$$A_1 = -E_0 \quad \text{all other } A_l \text{'s zero}$$

Conclusion:

$$V(r, \theta) = -E_0 \left( r - \frac{R^3}{r^2} \right) \cos \theta$$

The first term  $-E_0 r \cos \theta$  is due to the external field. The electric field  $\mathbf{E}$  is obtained as

$$E_r = -\frac{\partial V(r, \theta)}{\partial r} = E_0 \left( 1 + \frac{2R^3}{r^3} \right) \cos \theta$$

$$E_\theta = -\frac{1}{r} \frac{\partial V(r, \theta)}{\partial \theta} = E_0 \left( 1 - \frac{R^3}{r^3} \right) \sin \theta$$

$$E_\phi = 0$$

At  $r = R$

$$E_r = 3E_0 \cos \theta, \quad E_\theta = 0$$



The electric field is normal to the surface of the sphere metal. The induced surface charge density is

$$\sigma(\theta) = \epsilon_0 E_r |_{r=R} = 3\epsilon_0 E_0 \cos \theta$$

As expected, it is positive in the northern hemisphere ( $0 \leq \theta \leq \frac{\pi}{2}$ ) and negative in the southern ( $\frac{\pi}{2} \leq \theta \leq \pi$ ). Note that  $\mathbf{E} = 0$  inside the metal sphere. So the tangential component is equal to zero for the inside and outside on the boundary, as is expected from the continuity of tangential components. The normal component of the electric field is not continuous.

**((Mathematica))**

```
Clear["Global`*"];
```

```
r2xRule = {r →  $\sqrt{x^2 + y^2 + z^2}$ ,  $\theta \rightarrow \text{ArcCos}\left[\frac{z}{\sqrt{x^2 + y^2 + z^2}}\right]$ ,
```

```
 $\phi \rightarrow \text{ArcTan}[x, y]$ };
```

```
V1 = -E $\theta$   $\left(r - \frac{R^3}{r^2}\right) \text{Cos}[\theta]$ ;
```

```
rule1 = {R → 1, E $\theta$  → 1};
```

```
V11 = V1 /. rule1 /. r2xRule /. y → 0 // Simplify;
```

```
Ex1 = -D[V11, x];
```

```
Ez1 = -D[V11, z];
```

```
g1 = ContourPlot[Evaluate[Table[V11 ==  $\alpha$ , { $\alpha$ , -4, 4, 0.1}]],
```

```
{x, -3, 3}, {z, -3, 3},
```

```
ContourStyle → Table[{Hue[0.01 i], Thick}, {i, 0, 80}],
```

```
Epilog → {Black, Thick, Circle[{0, 0}, 1]},
```

```
RegionFunction → Function[{x, z},  $x^2 + z^2 > 1$ ]];
```

```
g2 = StreamPlot[{Ex1, Ez1}, {x, -3, 3}, {z, -3, 3},
```

```
StreamPoints → 80,
```

```
RegionFunction → Function[{x, z},  $x^2 + z^2 > 1$ ]];
```

```
h1 = Show[g1, g2, PlotRange → All];
```

```
h2 = Graphics[{Black, Thin, Arrowheads[0.03],
```

```
Arrow[{{-3, 0}, {3, 0}}, Arrow[{{0, -3}, {0, 3}}],
```

```
Text[Style["x", Black, 15, Italic], {2.8, -0.2}],
```

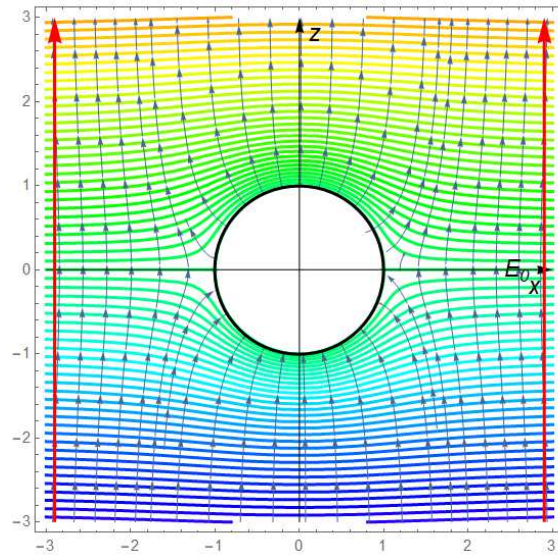
```
Text[Style["z", Black, 15, Italic], {0.2, 2.8}], Red,
```

```
Thick, Arrowheads[0.05], Arrow[{{-2.9, -3}, {-2.9, 3}}],
```

```
Arrow[{{2.9, -3}, {2.9, 3}}],
```

```
Text[Style["E $\theta$ ", Black, 15, Italic], {2.6, 0}]]];
```

```
Show[h1, h2]
```



## APPENDIX-I

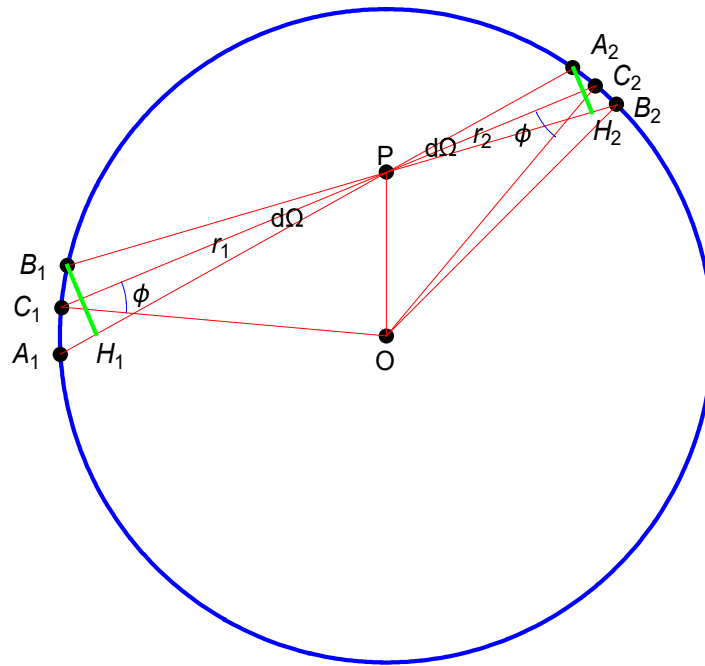
### Proof:

We verify the Coulomb's law that the force between two point charges is proportional to  $r^{-2}$ , where  $r$  is the distance between the two charges.

### Part I

We consider a hollow spherical shell with uniform surface charge density. By considering the two small patches at the ends of the thin cones. We show that the electric field at any point P in the interior of the shell is zero. This then implies that the electric potential is constant throughout the interior. (E.M. Purcell and D.J. Morin, Electricity and Magnetism, 3<sup>rd</sup> edition (Cambridge, 2013)).

The electric field inside a uniform spherical conducting shell of charge is zero. It is true only if the Coulomb force depends exactly on the square of the distance. We consider a cone with apex at P and extending on either side to cut out surface elements  $dA_1$  and  $dA_2$ . Let  $r_1$  and  $r_2$  be the distances of these elements from the point P. If  $\sigma$  is the surface charge density, the field at P due to elements are  $\frac{\sigma dA_1}{4\pi\epsilon_0 r_1^2}$  and  $\frac{\sigma dA_2}{4\pi\epsilon_0 r_2^2}$  and act in opposite directions.



Surface area  $B_1C_1A_1$ :  $dA_1$

Surface area  $B_2C_2A_2$ :  $dA_2$

Surface area  $B_1H_1$ :  $r_1^2 d\Omega_1$

Surface area  $A_2H_2$ :  $r_2^2 d\Omega_2$

The angles:

$$\angle C_1B_1H_1 = \phi, \quad \angle C_2B_2H_2 = \phi$$

Thus we have

$$dA_1 \sin \phi = r_1^2 d\Omega, \quad dA_2 \sin \phi = r_2^2 d\Omega$$

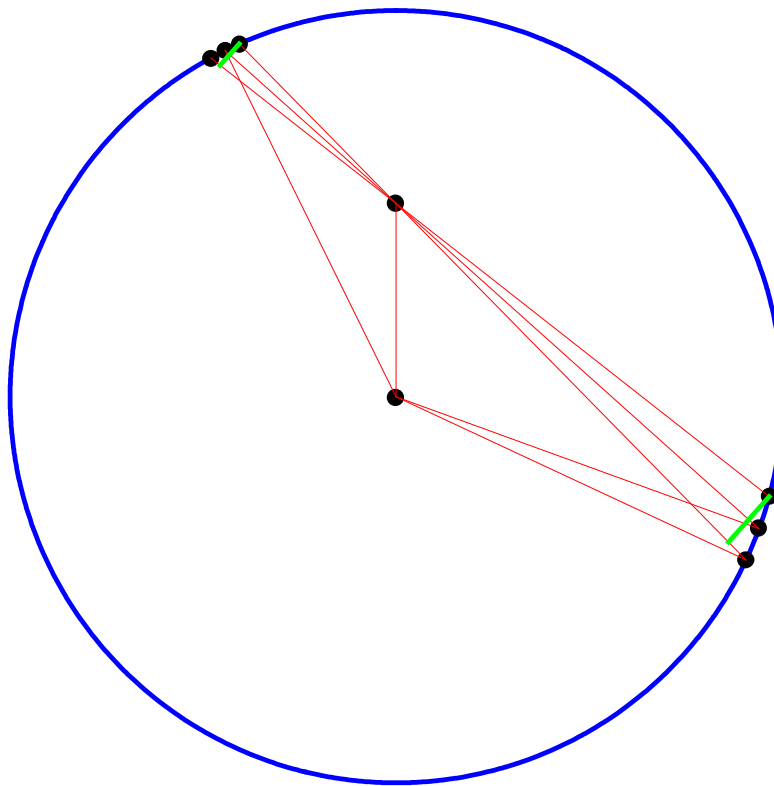
where  $d\Omega$  is the solid angle subtended at P by the two elements of area.

The electric field at the point P is

$$\begin{aligned} \frac{\sigma dA_1}{4\pi\epsilon_0 r_1^2} - \frac{\sigma dA_2}{4\pi\epsilon_0 r_2^2} &= \frac{\sigma}{4\pi\epsilon_0} \left( \frac{dA_1}{r_1^2} - \frac{dA_2}{r_2^2} \right) \\ &= \frac{\sigma}{4\pi\epsilon_0} \left( \frac{d\Omega}{\sin\phi} - \frac{d\Omega}{\sin\phi} \right) \\ &= 0 \end{aligned}$$

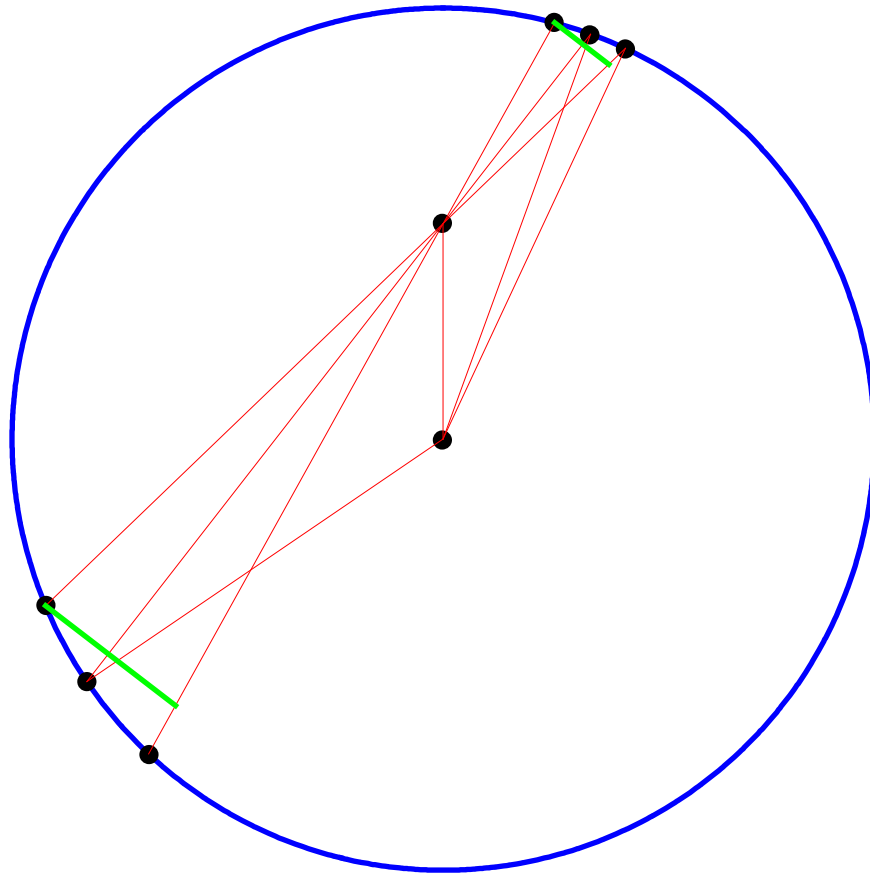
Hence the contributions to the field due to the two elements being equal and opposite, so cancel exactly.

((**Note**)) The same figures as above for different configuration.



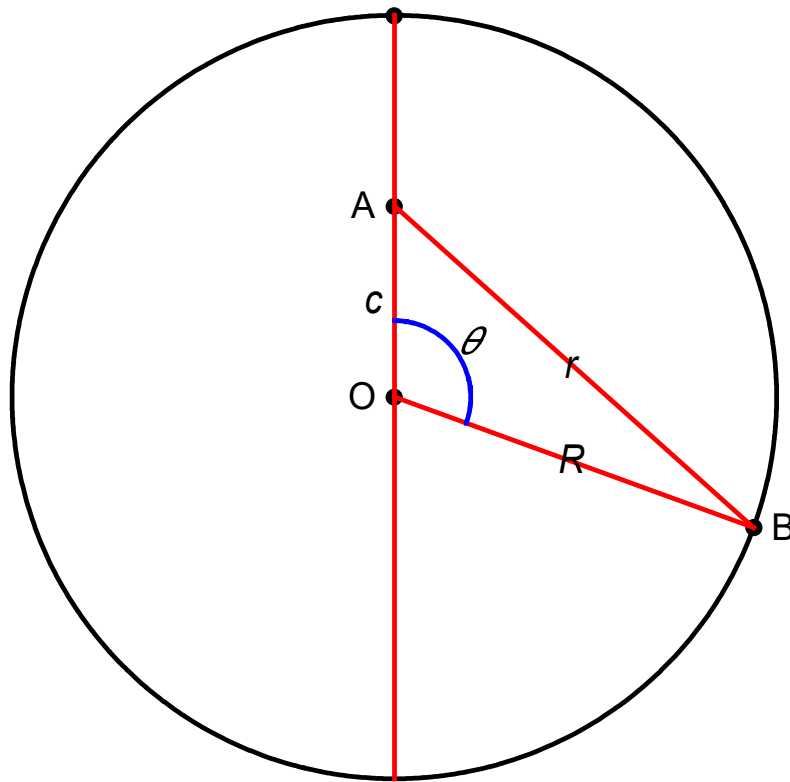
## REFERENCES

E.M. Purcell and D.J. Morin, Electricity and Magnetism, 3<sup>rd</sup> edition (Cambridge, 2013).



---

**Part-2**



Suppose that we start to find the law of electric force such that there shall be no change on the inner sphere. Let us assume a law of force such that the repulsion between two charges  $q, q'$  at a distance  $r$  apart is  $qq'\phi(r)$ . Let us calculate the electric potential at a point inside the sphere due to a charge spread entirely over the surface of the sphere.

$$V(c) = \int \phi(r) \sigma 2\pi R^2 \sin \theta d\theta$$

where

$$r^2 = c^2 + R^2 - 2cR \cos \theta$$

and

$$rdr = cR \sin \theta d\theta$$

Thus we have

$$\begin{aligned}
 V(c) &= \int \phi(r) \sigma 2\pi R^2 \frac{rdr}{cR} \\
 &= \frac{\sigma 2\pi R}{c} \int r\phi(r)dr \\
 &= \frac{Q}{2cR} \int_{R-c}^{R+c} r\phi(r)dr
 \end{aligned}$$

where  $R - c \leq r \leq R + c$  and

$$\sigma = \frac{Q}{4\pi R^2}$$

We note that

$$f(r) = \int_{\infty}^r r\phi(r)dr,$$

and

$$f'(r) = r\phi(r).$$

Then we get the electric potential as

$$\begin{aligned}
 V(c) &= \int \phi(r) \sigma 2\pi R^2 \frac{rdr}{cR} \\
 &= \frac{\sigma 2\pi R}{c} \int r\phi(r)dr \\
 &= \frac{Q}{2cR} [f(R+c) - f(R-c)]
 \end{aligned}$$

$V(c) = k$ , which is independent of  $c$ .

$$2ckR = Q[f(R+c) - f(R-c)]$$

Taking a derivative of both sides with respect to  $c$ ,

$$2kR = Q[f'(R+c) + f'(R-c)]$$

or

$$f''(R+c) - f''(R-c) = 0$$

Suppose that



$$f''(r) = A$$

$$f'(r) = Ar + B = r\phi(r)$$

or

$$\phi(r) = A + \frac{B}{r}$$

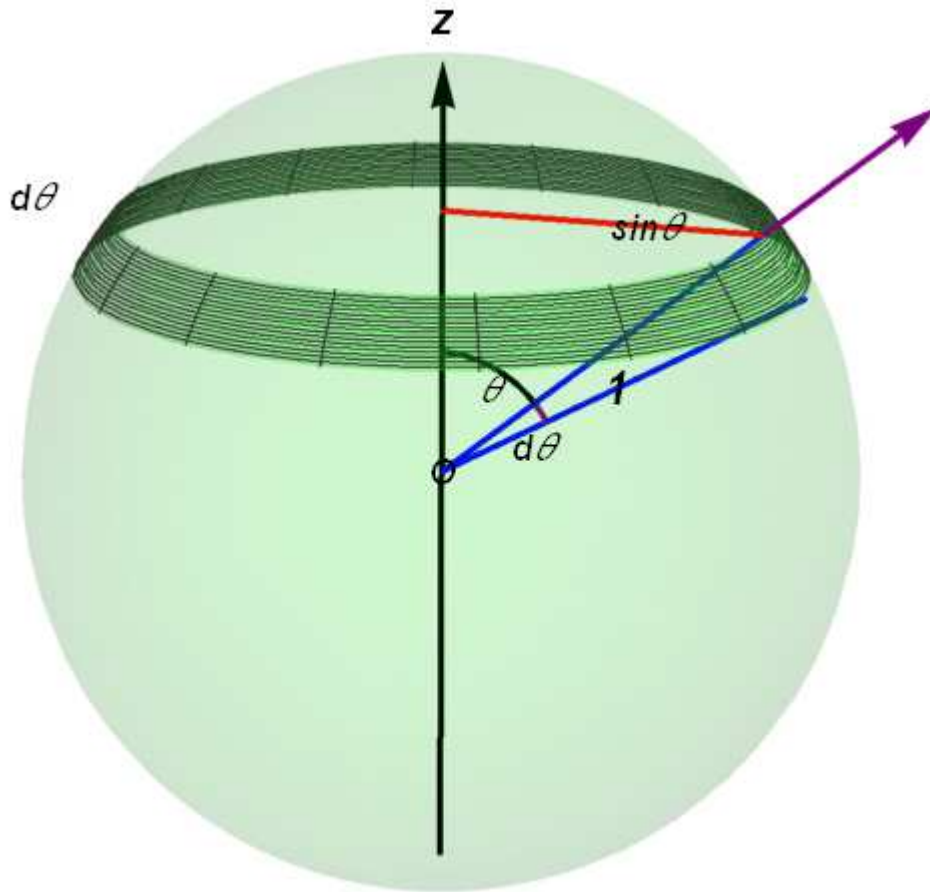
The electric field is

$$E = -\frac{d\phi(r)}{dr} = -\frac{B}{r^2} \quad (\text{Coulomb's law})$$

#### **REFERENCE**

James Jeans, The Mathematical Theory of Electricity and Magnetism, Fifth edition (Cambridge, 1963).

#### **APPENDIX-II**

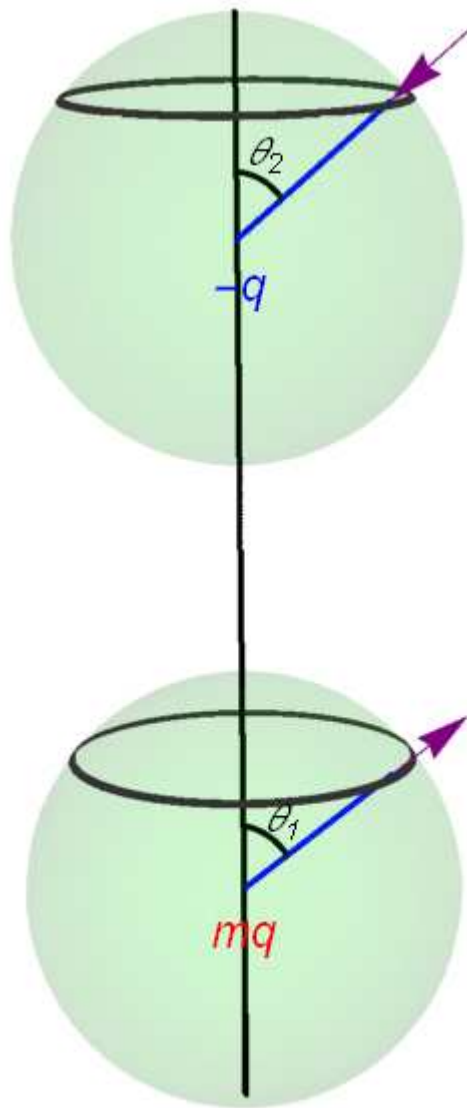


The solid angle of a cone with its apex at the apex of the solid angle, and with apex angle  $2\theta$ , is the area of a spherical cap on a unit sphere is obtained as follows.

$$\begin{aligned}\Omega(\theta) &= \int_0^\theta 2\pi \sin \theta d\theta \\ &= 2\pi[-\cos \theta]_0^\theta \\ &= 2\pi(1 - \cos \theta)\end{aligned}$$

The total electric flux coming from a point charge with  $q$ , over the solid angle  $\Omega(\theta)$  is

$$\Phi = \frac{q}{\epsilon_0} \frac{\Omega(\theta)}{4\pi} = \frac{q}{\epsilon_0} \frac{2\pi}{4\pi} (1 - \cos \theta) = \frac{q}{2\epsilon_0} (1 - \cos \theta).$$



Suppose that there are two charges with  $+mq$  ( $m > 2$ ) and  $-q$ . Among the electric field lines starting from the charge  $+mq$ , a part of them enters into the charge with  $-q$ , while the other lines go to infinity. We determine the critical angle  $\theta_c$ , below which all the lines enter into the point charge with  $-q$ .

The electric lines starting from the charge with  $+mq$  ( $m > 2$ ) over the solid angle  $\Omega(\theta_1)$

$$\Phi_1 = \frac{mq}{2\epsilon_0}(1 - \cos \theta_1).$$

The electric lines starting from the charge with  $-q$  over the solid angle  $\Omega(\theta_2)$

$$\Phi_2 = -\frac{q}{2\epsilon_0}(1 - \cos \theta_2).$$

The total electric lines

$$\Phi_{tot} = \frac{mq}{2\epsilon_0}(1 - \cos \theta_1) - \frac{q}{2\epsilon_0}(1 - \cos \theta_2),$$

are conserved both for the initial and final states. For the case (I), we have  $\theta_1 = \theta_c$  and  $\theta_2 = \pi$ . For the case (II), we have  $\theta_1 = 0$  and  $\theta_2 = 0$  (special case)

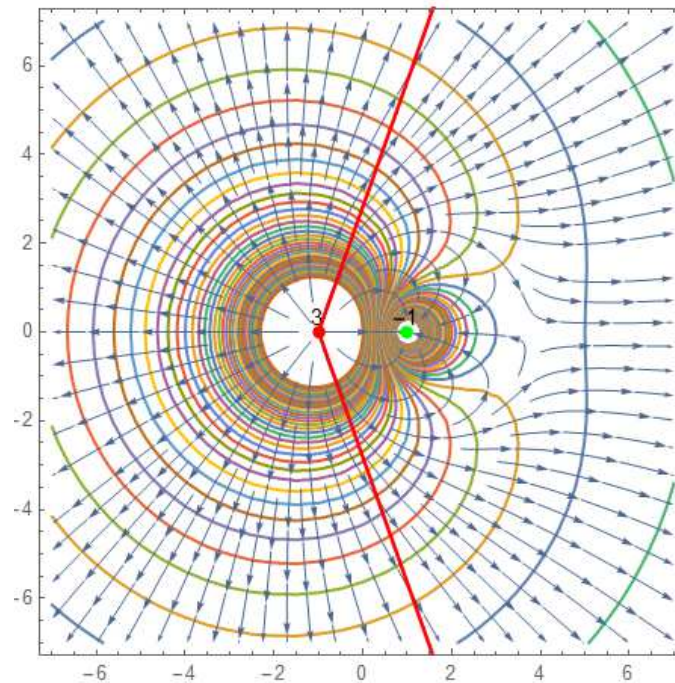
$$\frac{mq}{2\epsilon_0}(1 - \cos \theta_c) - \frac{q}{2\epsilon_0}(1 - \cos \pi) = \frac{mq}{2\epsilon_0}(1 - \cos 0) - \frac{q}{2\epsilon_0}(1 - \cos 0),$$

or

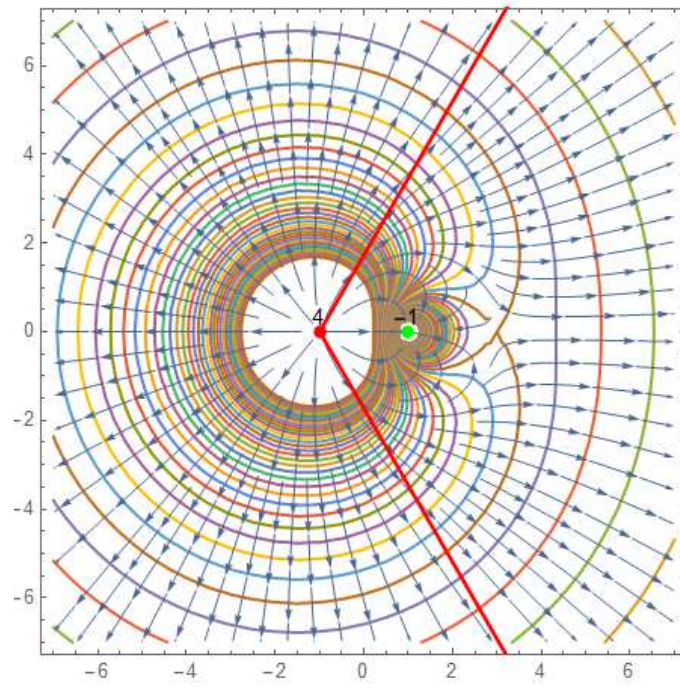
$$\cos \theta_c = 1 - \frac{2}{m}.$$

For  $m = 4$ ,  $\theta_c = \frac{\pi}{3}$ . For  $m = 6$ ,  $\theta_c = \frac{\pi}{6}$ .

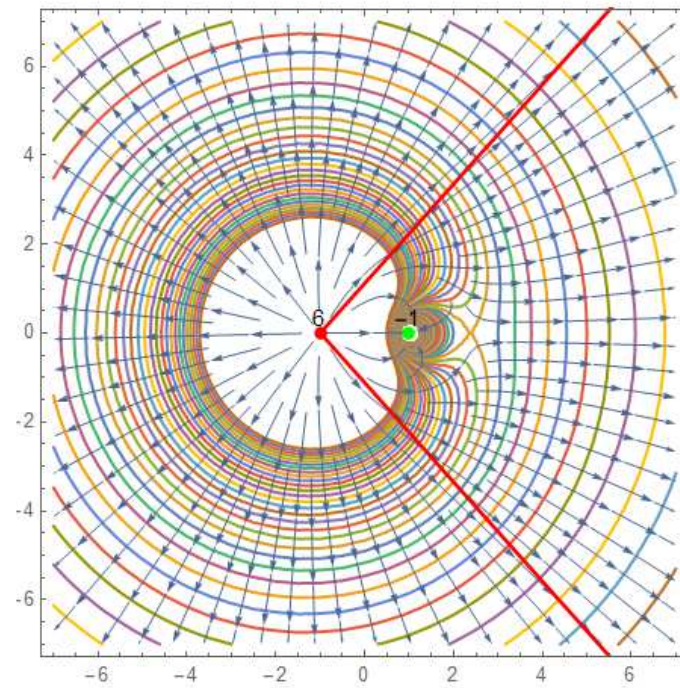
(a)  $m = 3$



(b)  $m = 4$

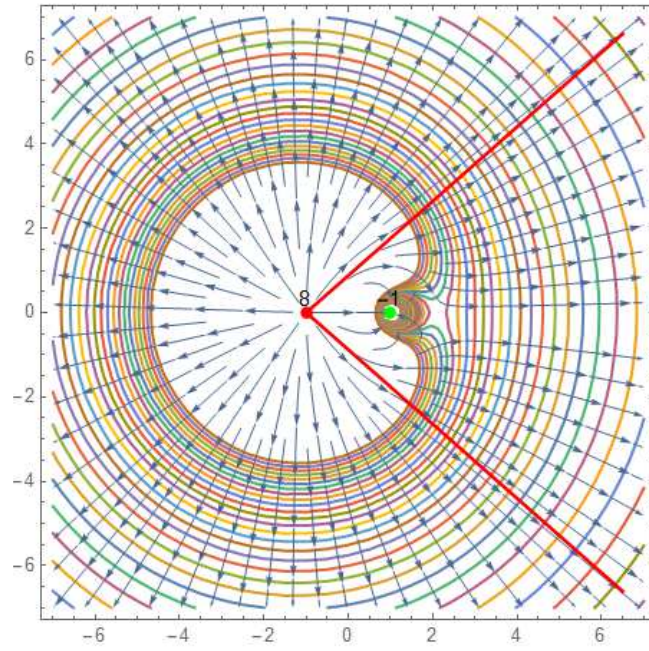


(c)  $m = 6$



(d)  $m = 8$





(d)

