

Chapter 34
Images
Masatsugu Sei Suzuki
Department of Physics, SUNY at Binghamton
(Date: August 04, 2019)

1. Fermat's principle

In optics, **Fermat's principle** or the **principle of least time**, named after French mathematician Pierre de Fermat, is the principle that the path taken between two points by a ray of light is the path that can be traversed in the least time. This principle is sometimes taken as the definition of a ray of light. Fermat's principle can be used to describe the properties of light rays reflected off mirrors, refracted through different media, or undergoing total internal reflection. It follows mathematically from Huygens' principle (at the limit of small wavelength).

1.1 Snell's law

We show that the Fermat's principle will give the Snell's law of refraction. Our problem is to go from A to B in the shortest time. The shortest transit time coincides with the actual path.

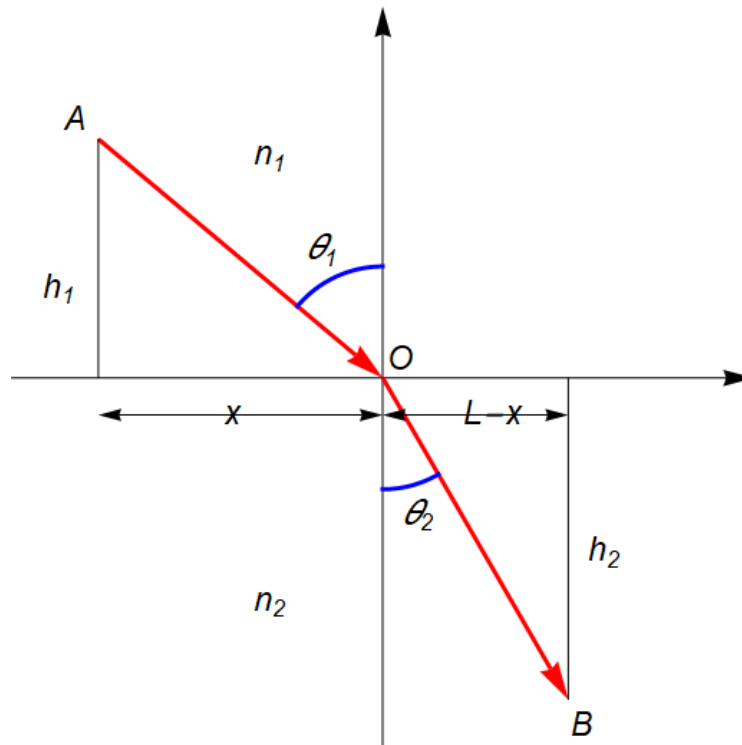

The total time for the light to propagate from the point A to B is given by

$$T = \frac{\overline{AO}}{\frac{c}{n_1}} + \frac{OB}{\frac{c}{n_2}}$$

or

$$T = \frac{1}{c} [n_1 \sqrt{x^2 + h_1^2} + n_2 \sqrt{(L-x)^2 + h_2^2}]$$

or

$$f(x) = cT(x) = n_1 \sqrt{x^2 + h_1^2} + n_2 \sqrt{(L-x)^2 + h_2^2}$$

Not that the velocity is given by c/n where n is the index of refraction. In order to get the minimum value of $f(x)$, we take a derivative of $f(x)$ with respect to x .

$$\frac{df(x)}{dx} = n_1 \frac{x}{\sqrt{x^2 + h_1^2}} - n_2 \frac{L-x}{\sqrt{(L-x)^2 + h_2^2}} = 0$$

The value of x for the least time is

$$n_1 \frac{x}{\sqrt{x^2 + h_1^2}} = n_2 \frac{L-x}{\sqrt{(L-x)^2 + h_2^2}}$$

Noting that $\frac{x}{\sqrt{x^2 + h_1^2}} = \cos \theta_1$, $\frac{L-x}{\sqrt{(L-x)^2 + h_2^2}} = \cos \theta_2$, we have

$$n_1 \cos\left(\frac{\pi}{2} - \theta_1\right) = n_2 \cos\left(\frac{\pi}{2} - \theta_2\right)$$

or

$$n_1 \sin \theta_1 = n_2 \sin \theta_2 \quad (\text{the Snell's law})$$

1.2 Parabolic mirror

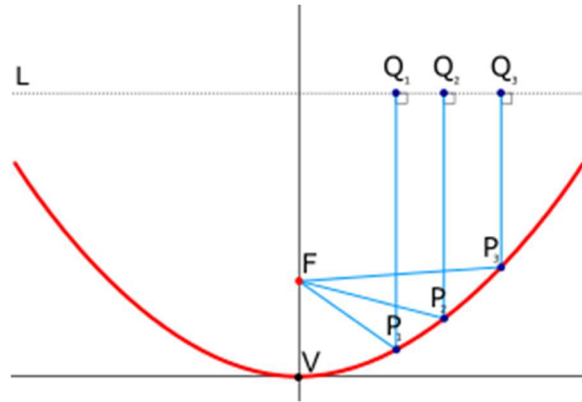

Parabolic mirror is based on the geometrical property of the paraboloid that the paths FP_1Q_1 , FP_2Q_2 , FP_3Q_3 are all the same length. So a spherical wave-front emitted at the focus F will be reflected into an outgoing plane wave L travelling parallel to the axis VF .

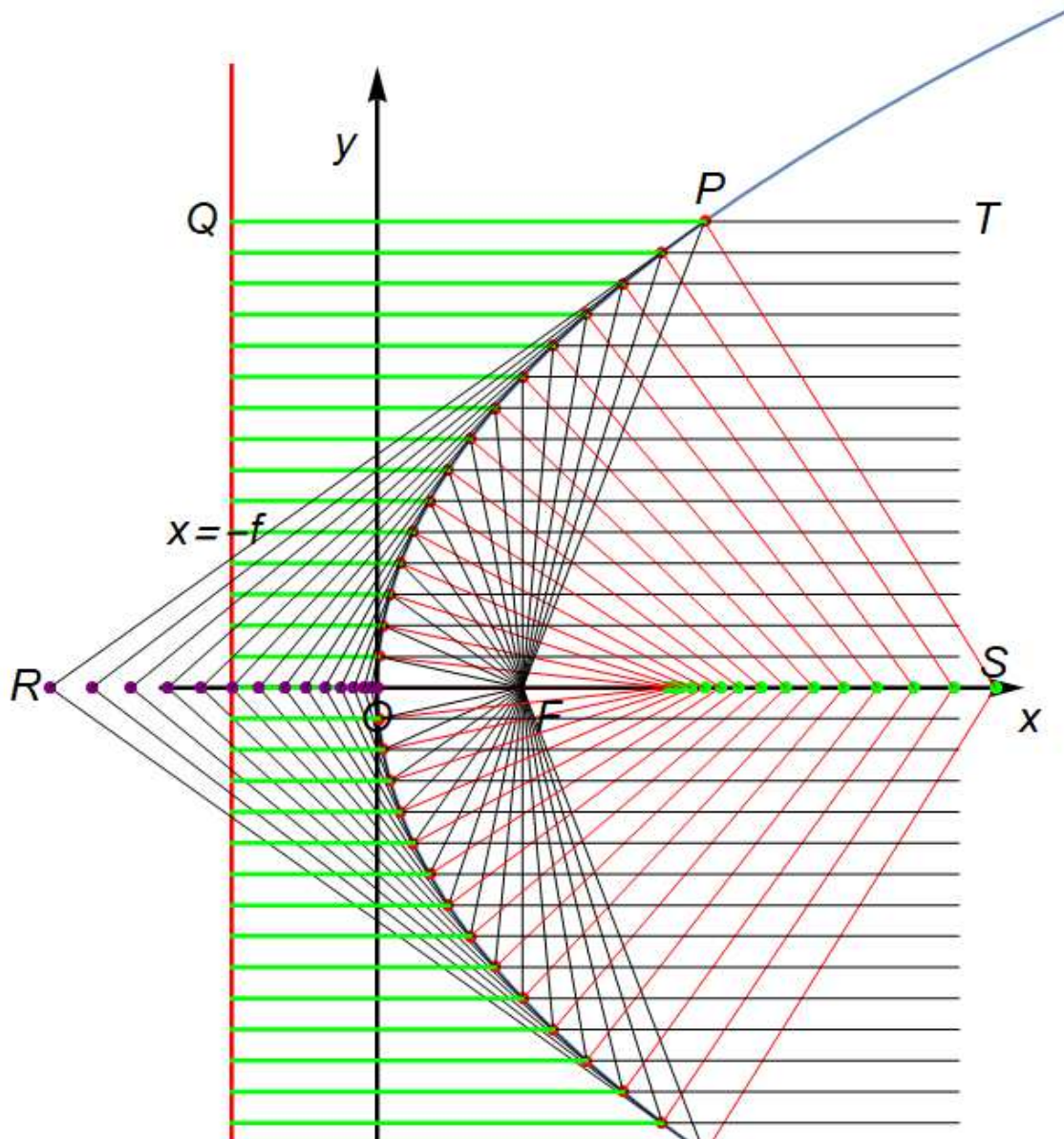

Fig. Parabola. F: Focal point. $\overline{OF} = (f, 0)$. $x = -f$ (directrix). O: origin (vertex). The parabola is the shape created by the points that are the same distance from the point F (focus) and a given line (the directrix). For any point $P(x, y)$ on the parabola, two lines \overline{PQ} and \overline{FQ} have the same length. The tangential line at the point P on the parabola intersects the x axis at the point R. Parallel rays coming into a parabolic mirror are focused at a point F: $T \rightarrow P \rightarrow F$. The line \overline{PS} is perpendicular to the tangential line \overline{PR} . $\angle FPS = \angle TPS$.

Path-1 = $x + f$:

(line \overline{QP})

$$\text{Path 2} = \sqrt{(x-f)^2 + y^2} : \quad (\text{line } \overline{FP})$$

From the definition of parabola, these two distances are equal each other.

$$(x+f)^2 = (x-f)^2 + y^2$$

or

$$y^2 = 4fx \quad (\text{Parabola})$$

1.3. Ellipsoidal mirror

We consider the elliptical mirror, where the light emitted from one of the focal point (S) and hit the mirror surface (Q), and subsequently goes to the other focal point (F). We know that the sum of the distances \overline{SQ} and \overline{QF} is the same when the point Q is on the ellipsoid. This means that there are many more paths that take the same (least) time between the same two end points (focal points).

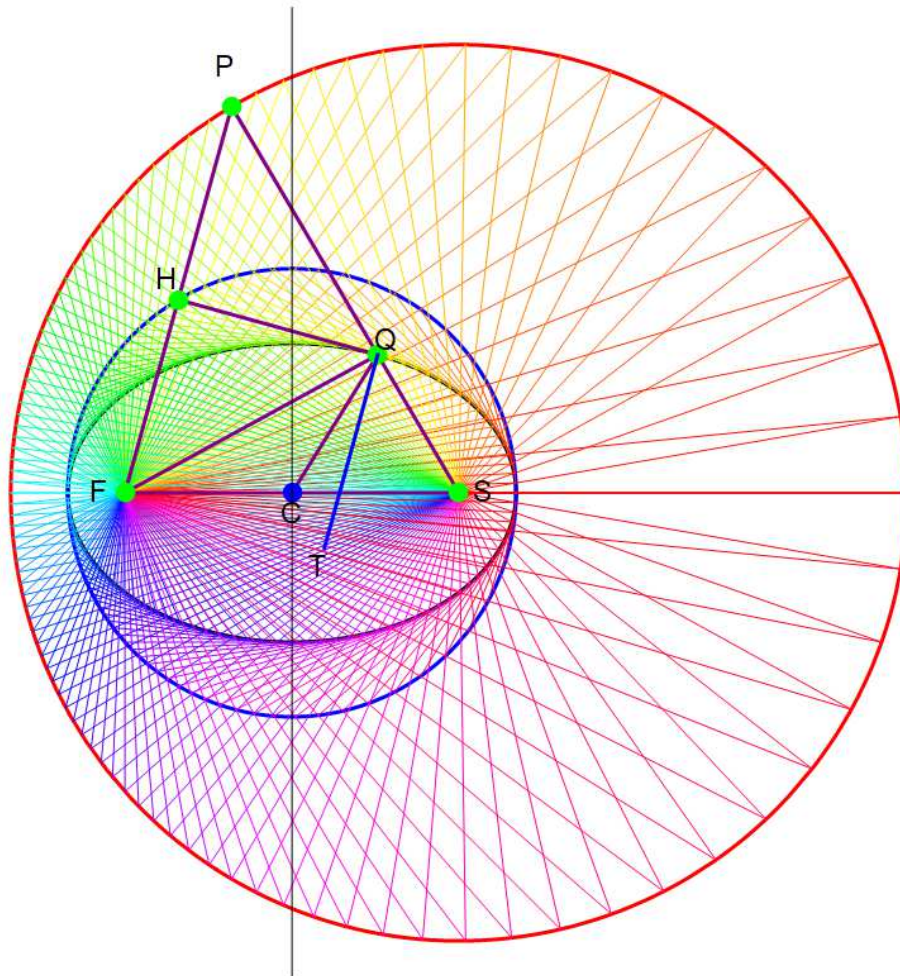

In this figure, \overline{FH} is perpendicular to the tangential line at the point Q on the ellipsoid. Suppose that the angle $\angle PFC$ is equal to α .

$$\angle QPF = \angle PFQ = \alpha$$

since $\overline{PQ} = \overline{QF}$, which leads to

$$\angle FQS = 2\alpha$$

The line \overline{QT} is parallel to the line \overline{FH} since \overline{QT} is perpendicular to the tangential line at the point Q on the ellipsoid. Then we conclude that

$$\angle FQT = \angle SQT = \alpha$$

In other words, the line \overline{QT} is the bisector line of $\angle FQS$

1.4. Spherical approximation to parabolic mirror

A precise parabolic mirror is more difficult to fabricate compared to spherical mirror. A sphere mirror is not quite a parabolic mirror, but we can see that a slice from the spherical mirror can be approximated by the parabolic mirror in a good approximation.

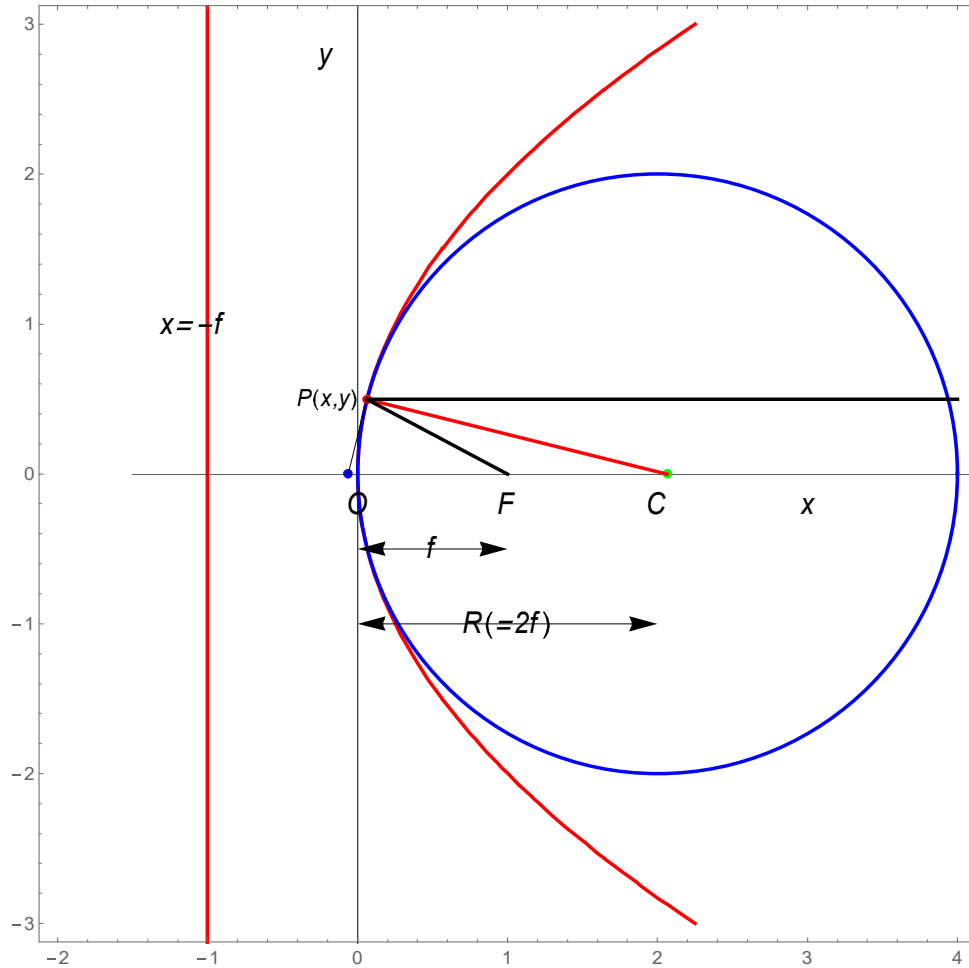

Fig. Comparison of a spherical and paraboloidal mirror.

We start with an equation of circle with radius R

$$(x - R)^2 + y^2 = R^2 \quad (\text{circle})$$

or

$$x^2 - 2Rx + R^2 + y^2 = R^2 \quad \text{or} \quad x^2 - 2Rx + y^2 =$$

When $x \approx 0$, we have

$$y^2 = 2Rx$$

which is the equation of parabola with $f = R/2$, where f is the focal length. Note that the parabola is expressed by $y^2 = 4fx$.

1.5 Spherical mirror

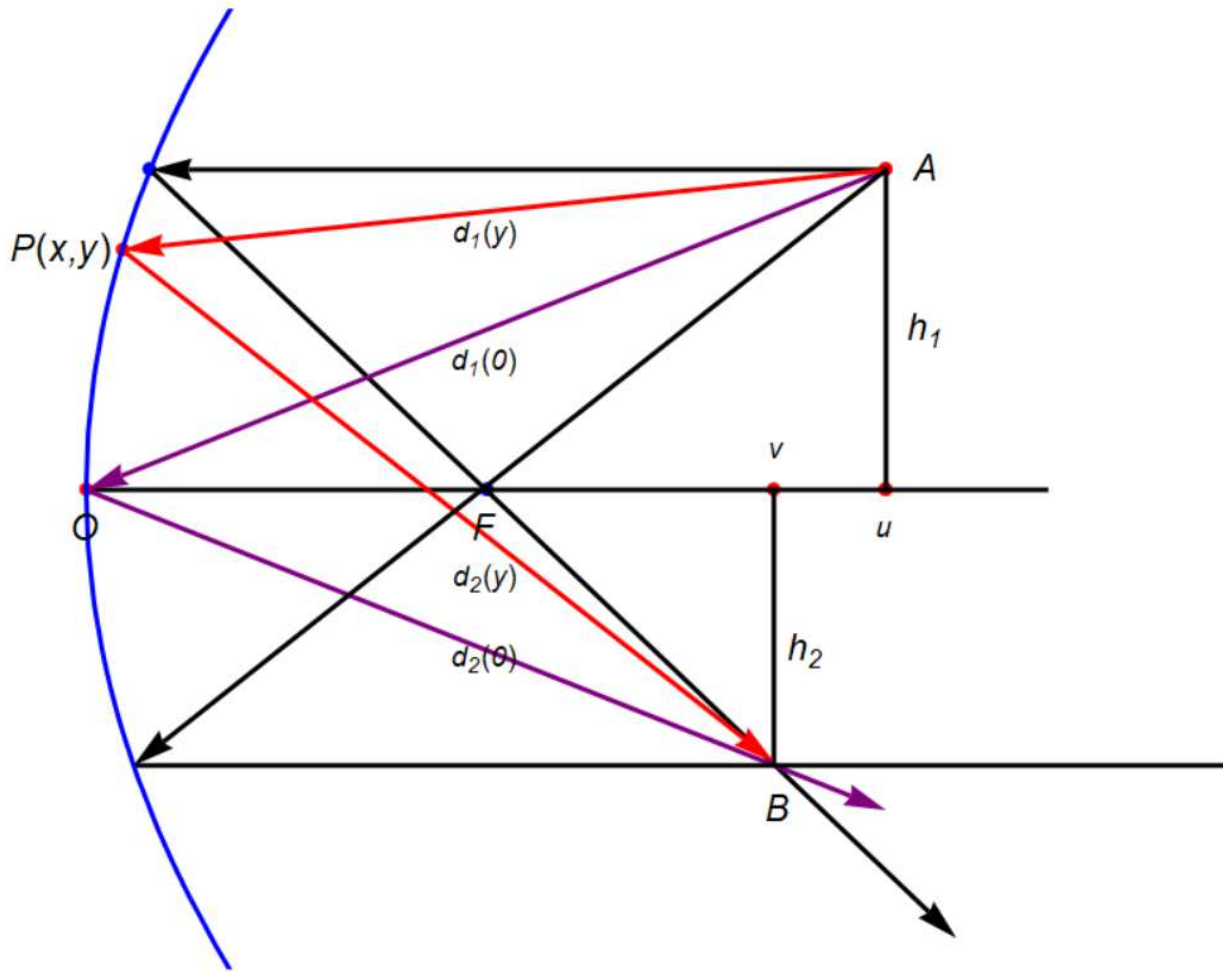

Fig. Spherical mirror. The point $P(x, y)$ is on the spherical mirror, where y is very small. $y^2 = 4fx$ with $f = R/2$.

We consider the two paths; (a) $A \rightarrow P(x, y) \rightarrow B$ [red line], and (b) $A \rightarrow O \rightarrow B$ (reflection) [purple line]. The time for the propagation of light through the path (a) should be the same as that through the path (b). The time taken is independent of y . The distances of the path (a) and path (b);

$$d_1(y) + d_2(y) = d_1(y=0) + d_2(y=0)$$

$$d_1(y) + d_2(y) = \sqrt{(h_1 - y)^2 + (u - x)^2} + \sqrt{(h_2 + y)^2 + (v - x)^2}$$

where $\overline{OA} = (u, h_1)$, $\overline{OB} = (v, -h_2)$, and $\overline{OP} = (x, y)$ with $y^2 = 4fx$. Note that u, v, f are large: h_1, h_2, y are small. Thus we get the approximation

$$\sqrt{h_1^2 + u^2} \approx u + \frac{h_1^2}{2u}, \quad \sqrt{h_2^2 + v^2} \approx v + \frac{h_2^2}{2v}$$

leading to

$$d_1(y=0) + d_2(y=0) = u + v + \frac{h_1^2}{2u} + \frac{h_2^2}{2v}$$

We also have

$$\begin{aligned} d_1(y) + d_2(y) &= \sqrt{h_1^2 - 2h_1y + y^2 + u^2 - 2ux + x^2} \\ &\quad + \sqrt{h_2^2 + 2h_2y + y^2 + v^2 - 2vx + x^2} \\ &\approx \sqrt{h_1^2 - 2h_1y + y^2 + u^2 - 2ux} \\ &\quad + \sqrt{h_2^2 + 2h_2y + y^2 + v^2 - 2vx} \\ &= u + \frac{h_1^2 - 2h_1y + y^2 + u^2 - 2ux}{2u} \\ &\quad + v + \frac{h_2^2 + 2h_2y + y^2 + v^2 - 2vx}{2v} \end{aligned}$$

Thus we have

$$\begin{aligned} d_1(y) + d_2(y) - d_1(y=0) - d_2(y=0) &= \frac{-2h_1y + y^2 - 2ux}{2u} \\ &\quad + \frac{2h_2y + y^2 - 2vx}{2v} \\ &= y\left(-\frac{h_1}{u} + \frac{h_2}{v}\right) + \frac{1}{2}y^2\left(\frac{1}{u} + \frac{1}{v}\right) - 2x \\ &= y\left(-\frac{h_1}{u} + \frac{h_2}{v}\right) + \frac{1}{2}y^2\left(\frac{1}{u} + \frac{1}{v} - \frac{1}{f}\right) \end{aligned}$$

where $y^2 = 4fx$. The above equation should be independent of y . So we get the relation

$$\frac{h_1}{u} = \frac{h_2}{v}, \quad \frac{1}{u} + \frac{1}{v} = \frac{1}{f} \quad (\text{spherical mirror})$$

with $f = R/2$.

1.6 Thin lens: Lens make's equation

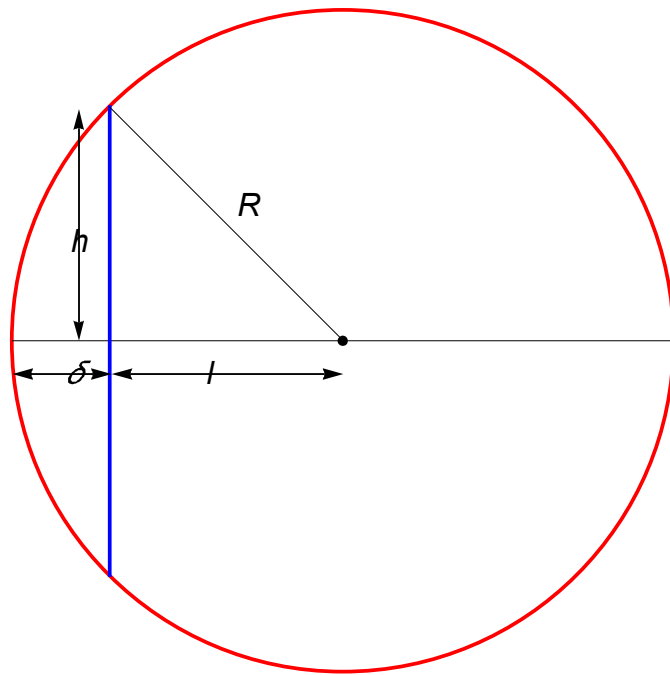
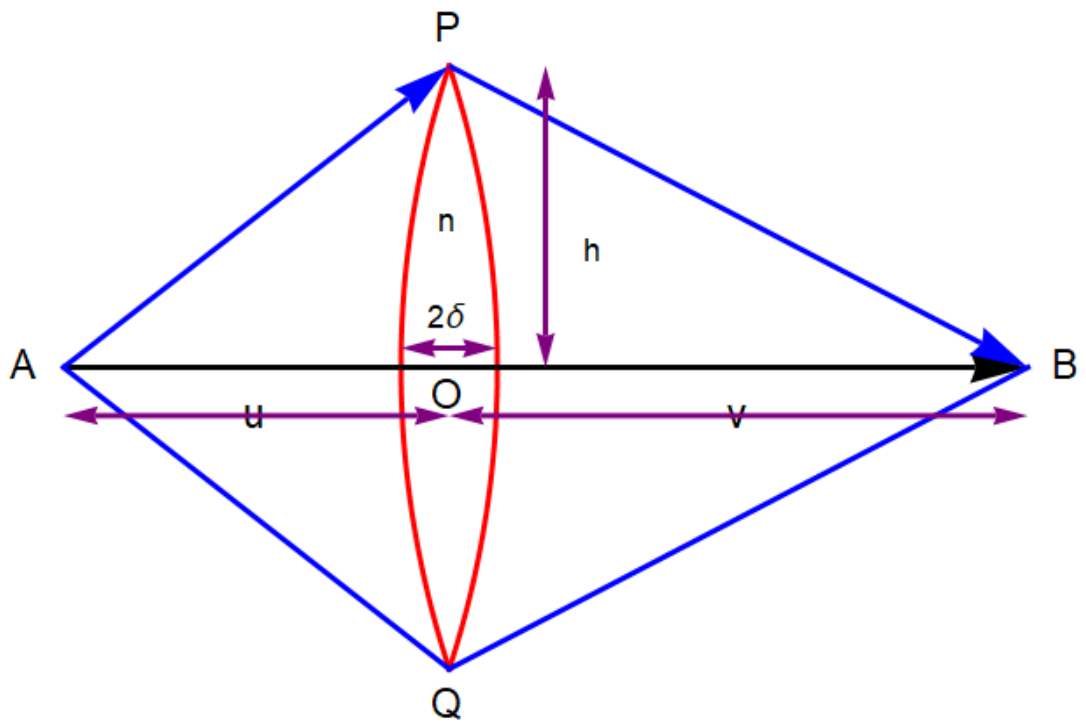

Fig. Thin concave lens. $2\delta = R - l$. $\overline{AO} = l$. R is the radius of lens.

Here we consider the two paths: path 1 ($A \rightarrow P \rightarrow B$) and path 2 ($A \rightarrow O \rightarrow B$) with the thickness of lens 2δ (see Fig.). The distances for these two paths are

$$s_1 = \overline{AP} + \overline{PB}, \quad s_2 = \overline{AOB},$$

where

$$s_1 = \sqrt{h^2 + u^2} + \sqrt{h^2 + v^2} \approx u + v + \frac{h^2}{2u} + \frac{h^2}{2v}$$

$$s_2 = u + v + 2(n-1)\delta$$

The velocity of light inside the lens is c/n , where n is the index of refraction. Note that

$$\delta = R - l \approx \frac{h^2}{2R},$$

since

$$l = \sqrt{R^2 - h^2} \approx R - \frac{h^2}{2R}$$

From the relation $s_1 = s_2$, we have

$$u + v + \frac{h^2}{2u} + \frac{h^2}{2v} = u + v + 2(n-1)\frac{h^2}{2R}$$

or

$$\frac{1}{u} + \frac{1}{v} = (n-1)\frac{2}{R} = \frac{1}{f}$$

In general

$$\frac{1}{f} = (n-1)\left(\frac{1}{R_1} + \frac{1}{R_2}\right) \quad (\text{Lens maker's equation})$$

REFERENCES

R.P. Feynman, R.B. Leighton, and M. Sands, *The Feynman Lectures on Physics volume II* (Basic Books, 2010).

R. Shankar, Fundamentals of Physics II; Electromagnetism, Optics, and Quantum Mechanics, Open Yale Course (Yale University, 2016).

2. Plane mirrors

2.1 Principle

Simplest possible mirror. Light rays leave the source and are reflected from the mirror. Point I is called the image of the object at point O. The image is virtual.

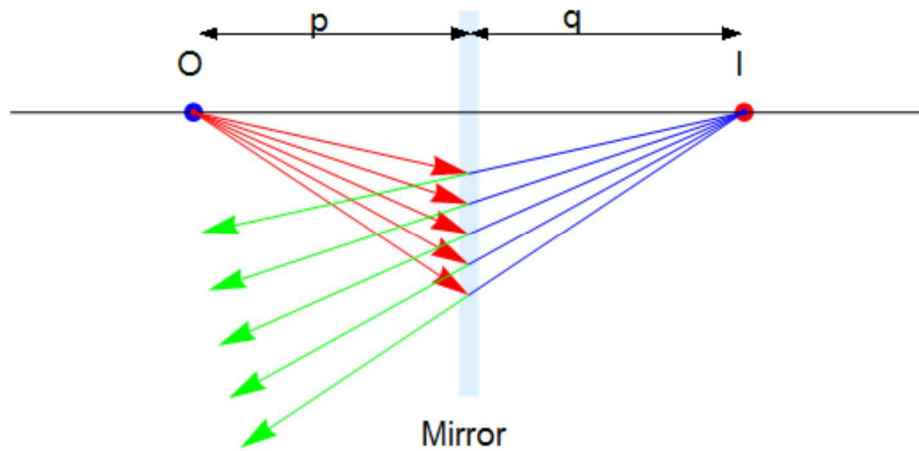

One ray starts at point P, travels to Q and reflects back on itself. Another ray follows the path PR and reflects according to the Law of Reflection. The triangles PQR and P'QR are congruent

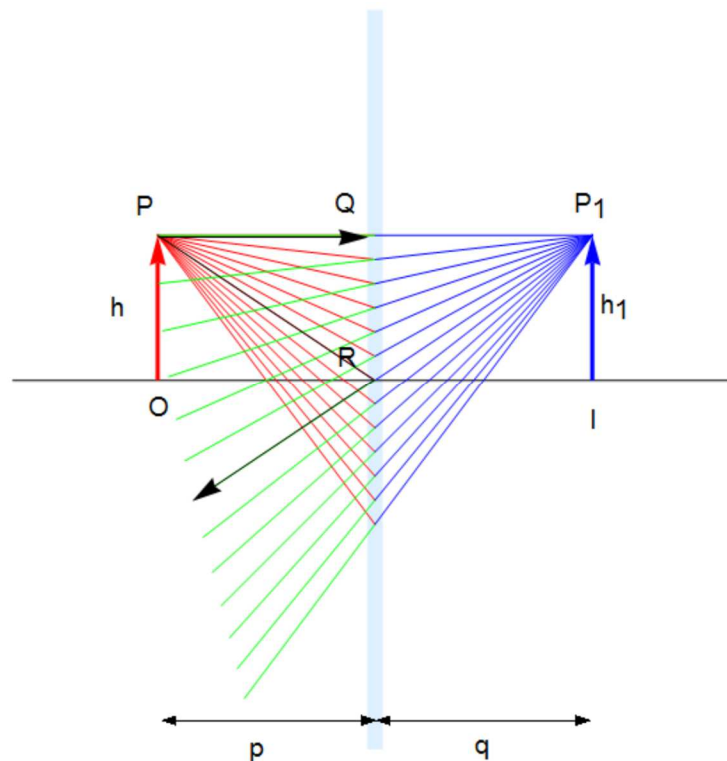

Fig. Plane mirror $h_1 = h'$.

To observe the image, the observer would trace back the two reflected rays to P'. Point P' is the point where the rays appear to have originated. The image formed by an object placed in front of a flat mirror is as far behind the mirror as the object is in front of the mirror. $p = |q|$

2.2 Lateral Magnification of a Flat Mirror

Lateral magnification, M , is defined as

$$M = \frac{h'}{h}$$

This is the general magnification for any type of mirror. It is also valid for images formed by lenses. Magnification does not always mean bigger, the size can either increase or decrease. M can be less than or greater than 1.

The lateral magnification of a flat mirror is 1. This means that $h' = h$ for all images

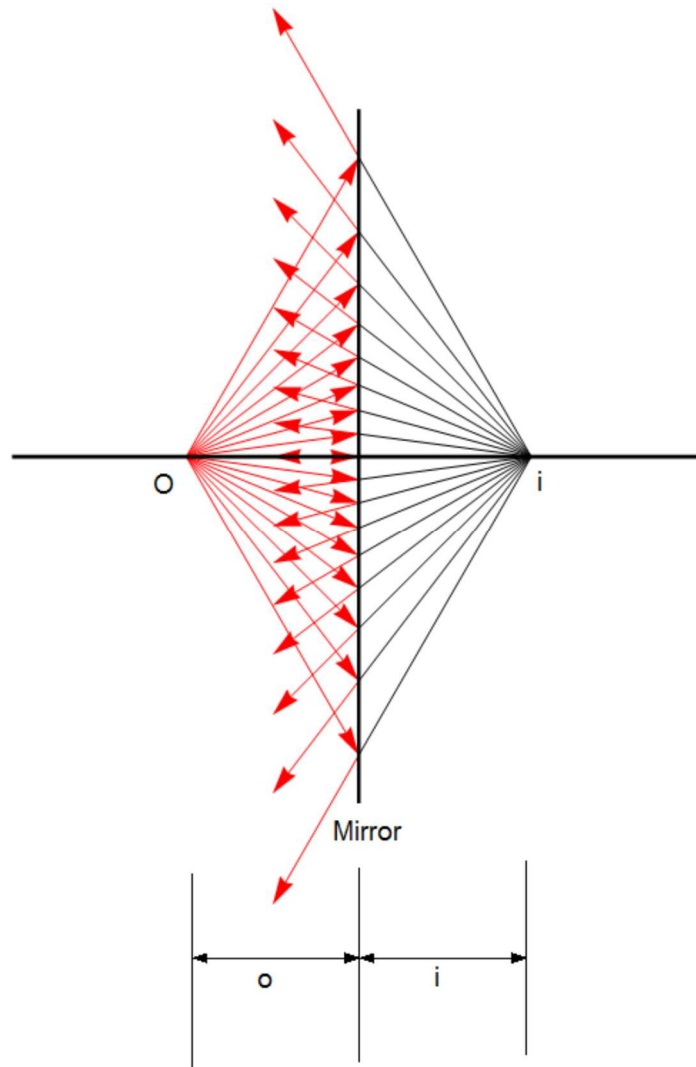
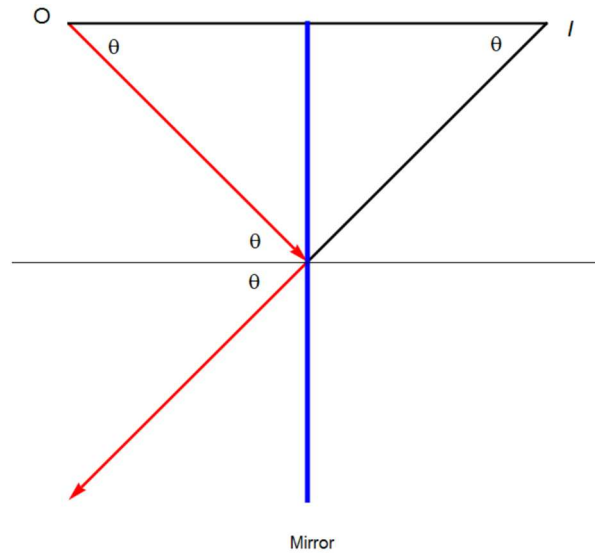

Fig. A point object O forms a virtual image I in a plane mirror. The figure is made using the Graphics of the Mathematica.



2.3 Reversals in a Flat Mirror

A flat mirror produces an image that has an apparent left-right reversal. For example, if you raise your right hand the image you see raises its left hand.

The reversal is not actually a left-right reversal. The reversal is actually a front-back reversal. It is caused by the light rays going forward toward the mirror and then reflecting back from it

2.4 Summary

- (a) The image is as far behind the mirror as the object is in front. $p = |q|$
- (b) The image is unmagnified.
The image height is the same as the object height.
 $h' = h$ and $M = 1$
- (c) The image is virtual.
- (d) The image is upright.
It has the same orientation as the object.
- (e) There is a front-back reversal in the image.

3. Spherical mirrors

A spherical mirror has the shape of a segment of a sphere. The mirror focuses incoming parallel rays to a point. A **concave spherical mirror** has the light reflected from the inner, or concave, side of the curve. A **convex spherical mirror** has the light reflected from the outer, or convex, side of the curve.

3.1. Concave mirror

3.1.1 Notation

The mirror has a radius of curvature of R . Its center of curvature is the point C . Point V is the center of the spherical segment. A line drawn from C to V is called the principal axis of the mirror

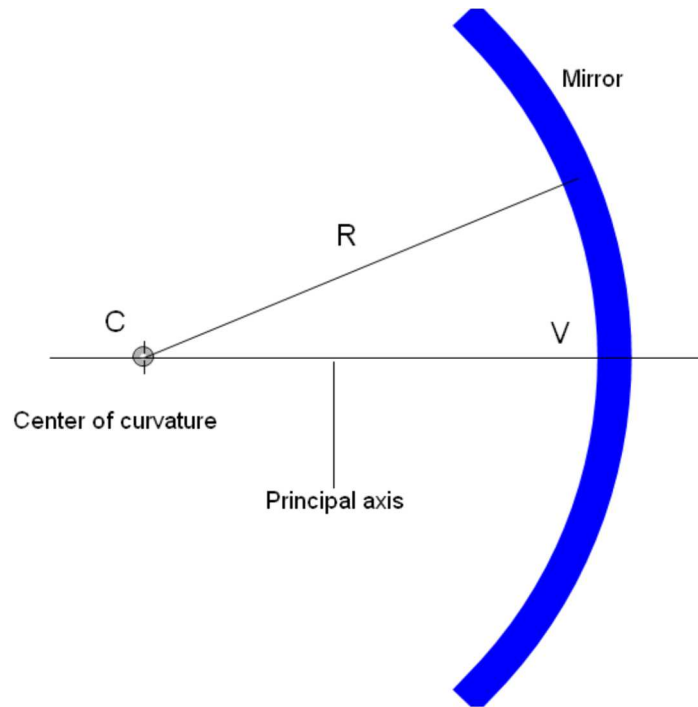

3.1.2 Paraxial rays

We use only rays that diverge from the object and make a small angle with the principal axis (A simplification model). Such rays are called paraxial rays. All paraxial rays reflect through the image point.

3.1.3 Spherical aberration

Rays that are far from the principal axis converge to other points on the principal axis. This produces a blurred image. The effect is called spherical aberration.

3.1.4 Image formed by a concave mirror

A geometric model can be used to determine the magnification of the image,

$$m = \frac{h'}{h} = -\frac{q}{p}$$

where h' is negative when the image is inverted with respect to the object

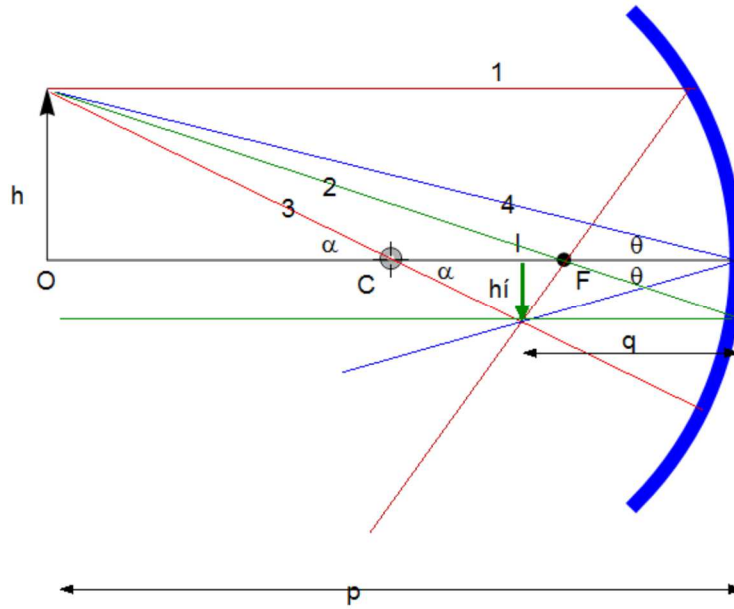

Geometry also shows the relationship between the image and object distances

$$\frac{1}{p} + \frac{1}{q} = \frac{2}{R} = \frac{1}{f}$$

This is called the mirror equation. f is the focal length ($f = R/2$). If p is much greater than R , then the image point is half-way between the center of curvature and the center point of the mirror. $p \rightarrow \infty$, then $1/p \approx 0$ and $q \approx R/2$.

3.1.5 Derivation of the formula

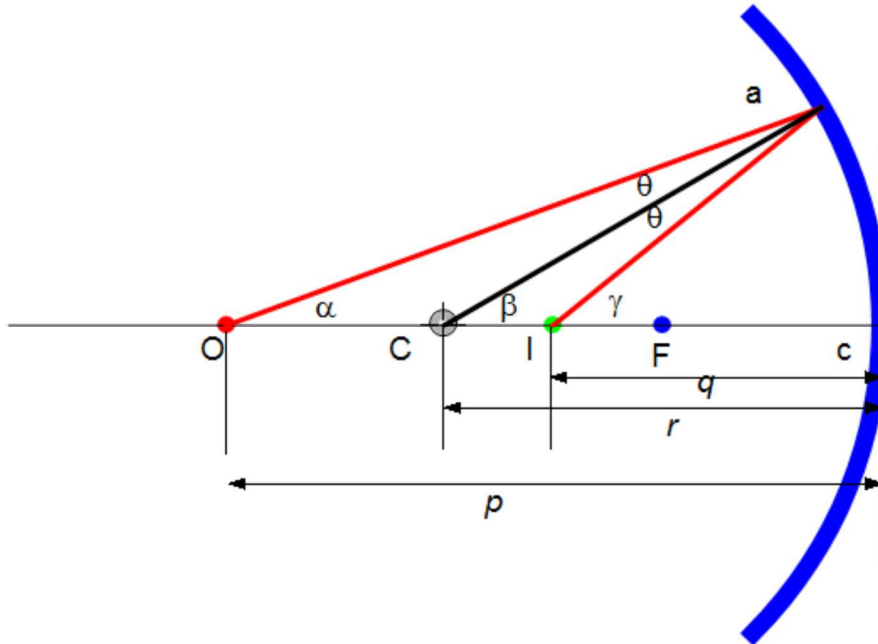

We have

$$\begin{aligned} \alpha + \theta &= \beta \\ \beta + \theta &= \gamma \end{aligned} \quad \text{or} \quad \alpha + \gamma = 2\beta$$

We have also

$$p \tan \alpha \approx r \tan \beta \approx q \tan \gamma$$

In the limit of small α , β , and γ ,

$$p\alpha = r\beta = q\gamma = k$$

Then we obtain

$$\frac{k}{p} + \frac{k}{q} = 2\frac{k}{r} \quad \text{or} \quad \frac{1}{p} + \frac{1}{q} = \frac{2}{r}$$

The lateral magnification m is defined by

$$m = -\frac{q}{p}$$

3.1.6 Focal length f

When the object is very far away, then $p \rightarrow \infty$ and the incoming rays are essentially parallel. In this special case, the image point is called the focal point. The distance from

the mirror to the focal point is called the focal length. The focal length is $\frac{1}{2}$ the radius of curvature;

$$f = \frac{R}{2}.$$

The laser beams are traveling parallel to the principal axis. The mirror reflects all the beams to the focal point. The focal point is where all the beams intersect. The focal point is dependent solely on the curvature of the mirror. It does not depend on the location of the object. It also does not depend on the material from which the mirror is made.

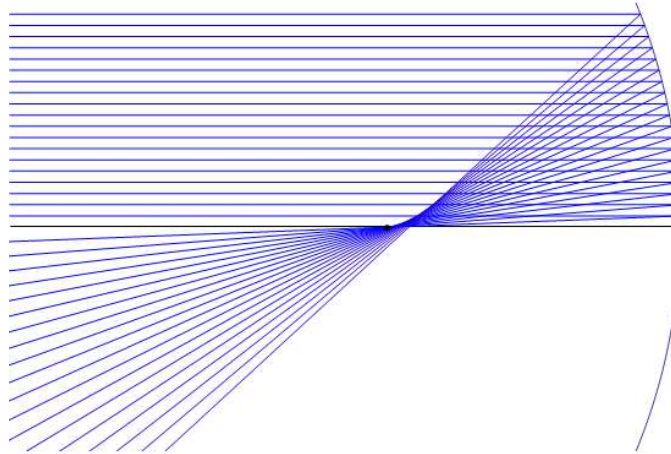

3.2. Convex mirrors

A convex mirror is sometimes called a diverging mirror. The light reflects from the outer, convex side. The rays from any point on the object diverge after reflection as though they were coming from some point behind the mirror. The image is virtual because the reflected rays only appear to originate at the image point. $p > 0$ and $q < 0$.

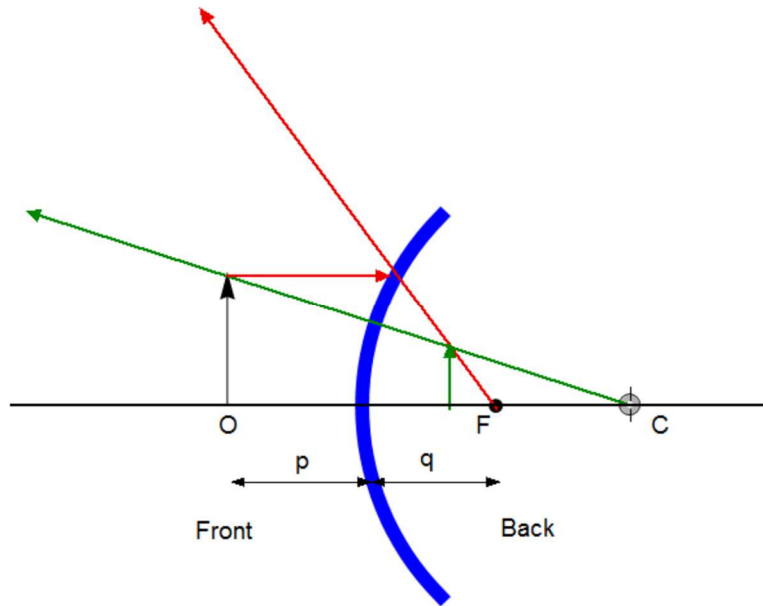

In general, the image formed by a convex mirror is upright, virtual, and smaller than the object.

3.3 The sign conventions

Spherical mirror

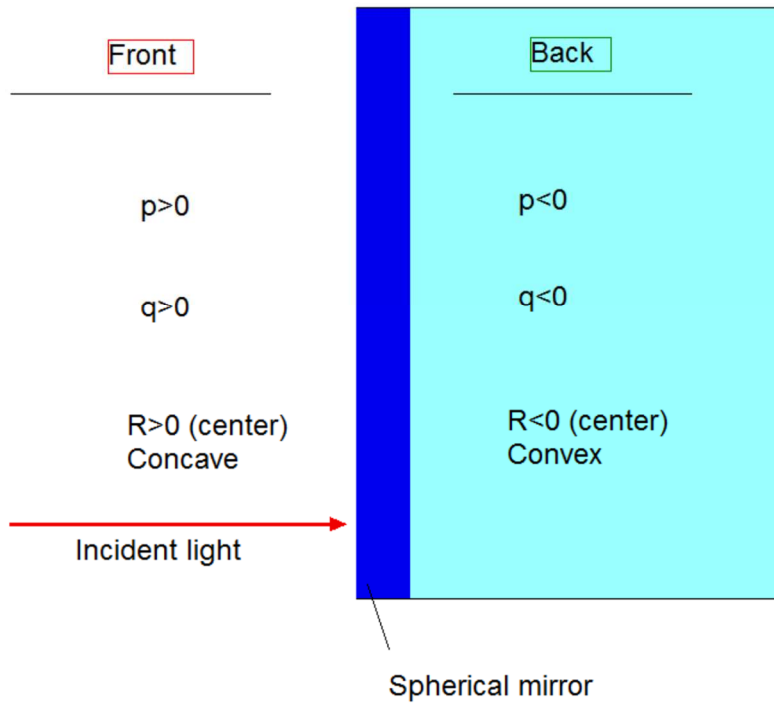

The region in which the light rays move is called the **front side** of the mirror. The other side is called the **back side** of the mirror. The sign conventions used apply to both concave and convex mirrors. The equations used for the concave mirror also apply to the convex mirror

Object	Positive when....	Negative when ...
Object location (p)	in front of mirror (real)	back of mirror (virtual)
Image location (q)	in front of mirror (real)	back of mirror (virtual)
Image height (h')	upright	inverted
Focal length (f) and radius (R)	concave	convex
Magnification (m)	upright	inverted

3.4 Ray Diagrams

A ray diagram can be used to determine the position and size of an image. They are graphical constructions which reveal the nature of the image. They can also be used to check the parameters calculated from the mirror and magnification equations.

To draw the ray diagram, you need to know the position of the object. The locations of the focal point and the center of curvature.

Three rays are drawn

- (i) They all start from the same position on the object.
- (ii) The intersection of any two of the rays at a point locates the image.
- (iii) The third ray serves as a check of the construction.

3.5 The Rays in a Ray Diagram – Concave Mirrors

- (i) Ray 1 is drawn from the top of the object O parallel to the principal axis and is reflected through the focal point, F.
- (ii) Ray 2 is drawn from the top of the object through the focal point F and is reflected parallel to the principal axis.
- (iii) Ray 3 is drawn through the center of curvature, C, and is reflected back on itself.

The rays actually go in all directions from the object. The three rays were chosen for their ease of construction. The image point obtained by the ray diagram must agree with the value of q calculated from the mirror equation.

3.5.1 Ray diagram for concave mirror, $p > R$

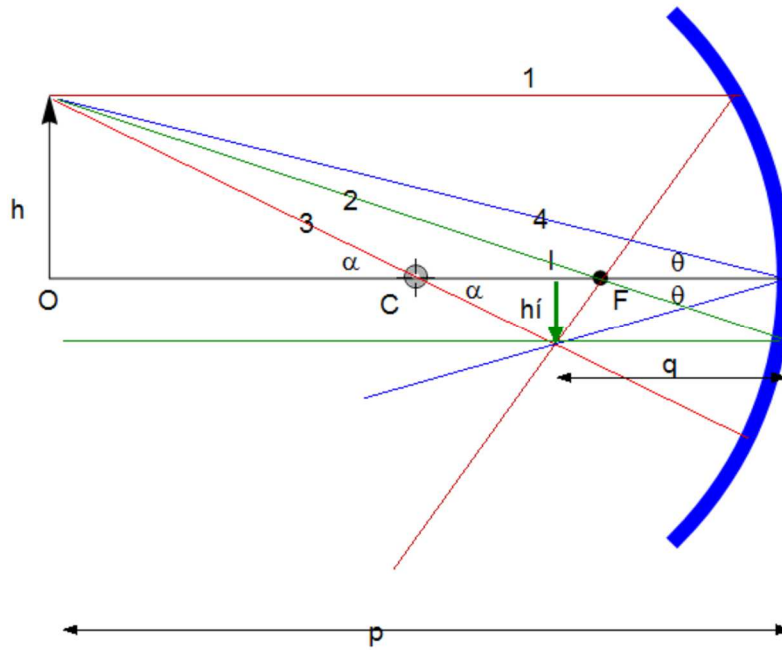

- (i) The center of curvature is between the object and the concave mirror surface ($f > 0$)
- (ii) The image is real ($q > 0$).
- (iii) The image is inverted ($m = -q/p < 0$).
- (iv) The image is smaller than the object (reduced).

3.5.2 Ray diagram for a concave mirror, $p < f$

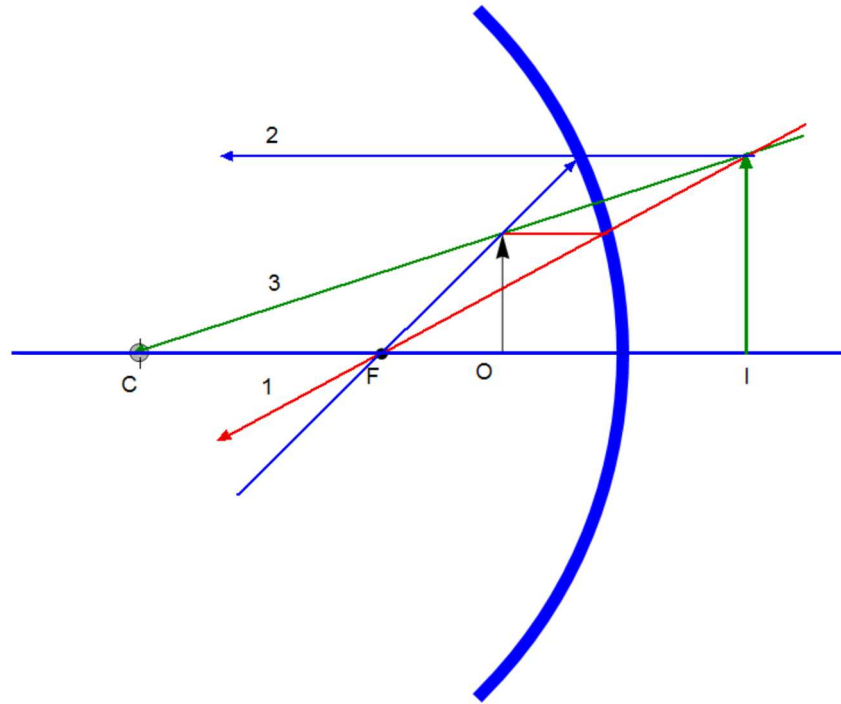

- (i) The object is between the mirror surface and the focal point.
- (ii) The image is virtual ($q < 0$).
- (iii) The image is upright ($m > 0$).
- (iv) The image is larger than the object (enlarged).

3.6 The Rays in a Ray Diagram – Convex Mirrors

- (i) Ray 1 is drawn from the top of the object parallel to the principal axis and is reflected as if coming from the focal point, F
- (ii) Ray 2 is drawn from the top of the object toward the focal point and is reflected parallel to the principal axis
- (iii) Ray 3 is drawn through the center of curvature, C, on the back side of the mirror and is reflected back on itself

Ray diagram for a convex mirror

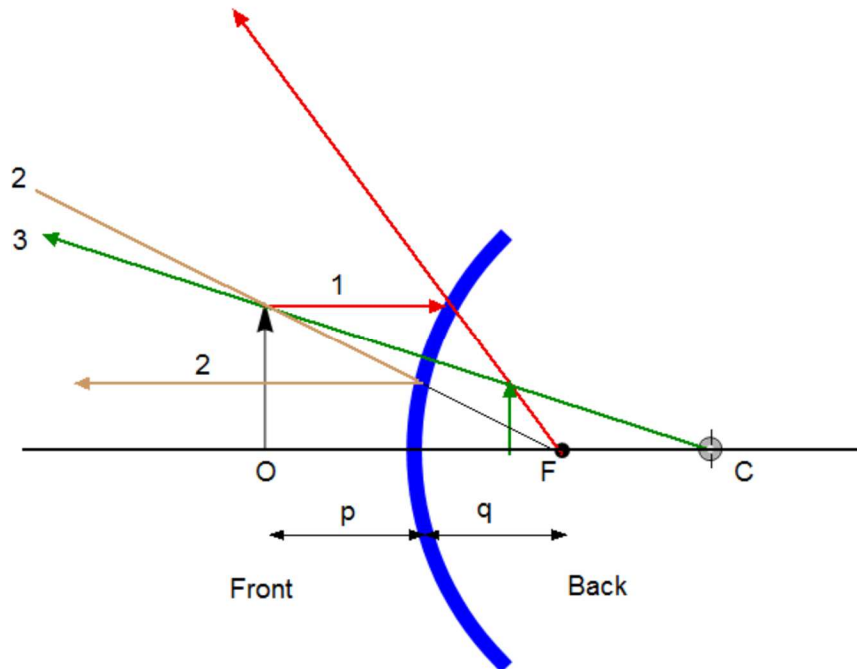

The object is in front of a convex mirror ($f < 0$).
 The image is virtual ($q < 0$).
 The image is upright ($m > 0$).
 The image is smaller than the object (reduced).

4. Images formed by refraction (spherical surface refraction)

4.1

Consider two transparent media having indices of refraction n_1 and n_2 . The boundary between the two media is a spherical surface of radius R .

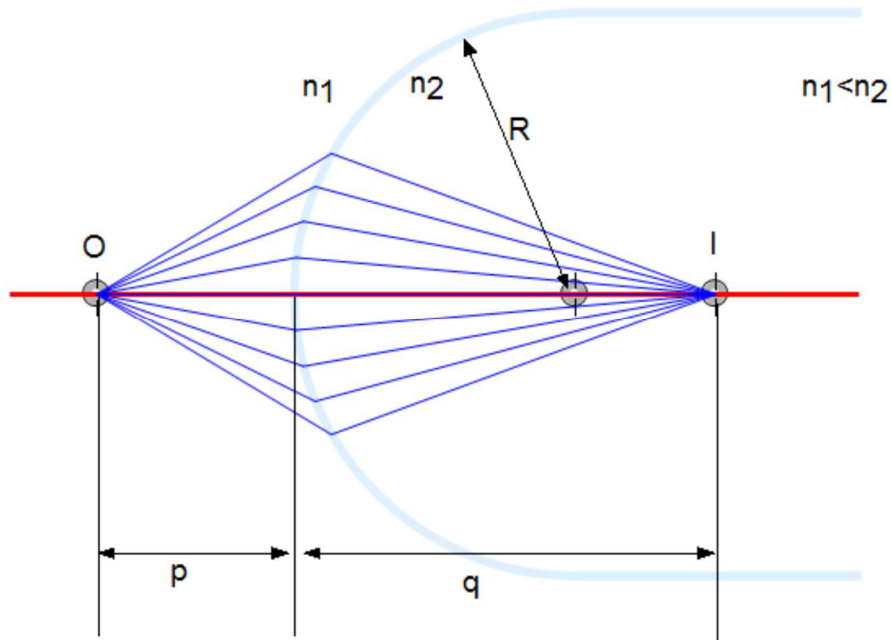

Fig. Figure is made by using the Graphics program of Mathematica. $n_1 < n_2$

We will consider the paraxial rays leaving O. All such rays are refracted at the spherical surface and focus at the image point, I. The relationship between object and image distances can be given by

$$\frac{n_1}{p} + \frac{n_2}{q} = \frac{n_2 - n_1}{R}$$

The side of the surface in which the light rays originate is defined as the front side. The other side is called the back side. Real images are formed by refraction in the back of the surface. Because of this, the sign conventions for q and R for refracting surfaces are opposite those for reflecting surfaces

Possible ways in which an image can be formed by refraction through a spherical surface of radius. We assume that the radius of the sphere is 1.

(a) $n_1 = 1, n_2 = 1.9, R = 1$

(i) $p = 0.5$ and $q = -1.72727$

$$\{p, q, n_1, n_2, R\} =$$

$$\{0.5, -1.72727, 1, 1.9, 1\}$$

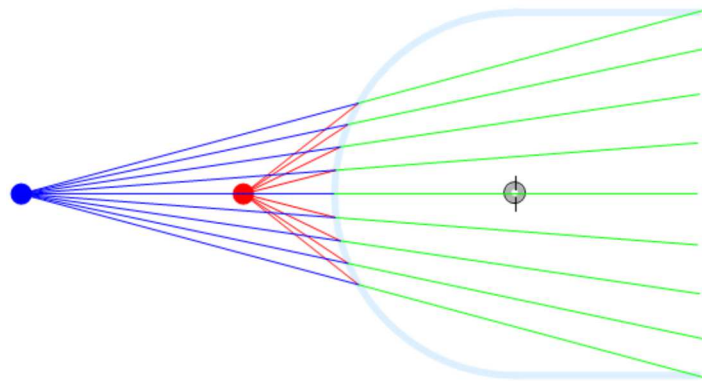

(ii) $p = 0.8$ and $q = -5.42857$

$$\{p, q, n_1, n_2, R\} =$$

$$\{0.8, -5.42857, 1, 1.9, 1\}$$

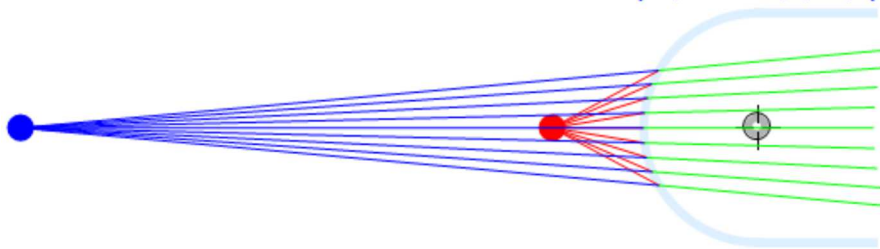

(iii) $p = 2$ and $q = 4.75$

$$\{p, q, n_1, n_2, R\} =$$

$$\{2, 4.75, 1, 1.9, 1\}$$

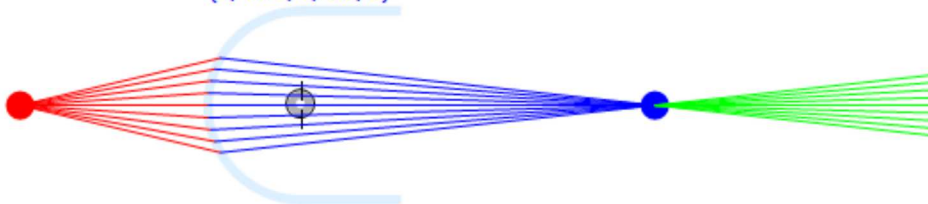

(b) $n_1 = 1.9, n_2 = 1.0, R = -1.0$

(i) $p = 0.8, q = -0.677966,$

$\{p, q, n1, n2, R\} =$
 $\{0.8, -0.677966, 1.9, 1., -1\}$

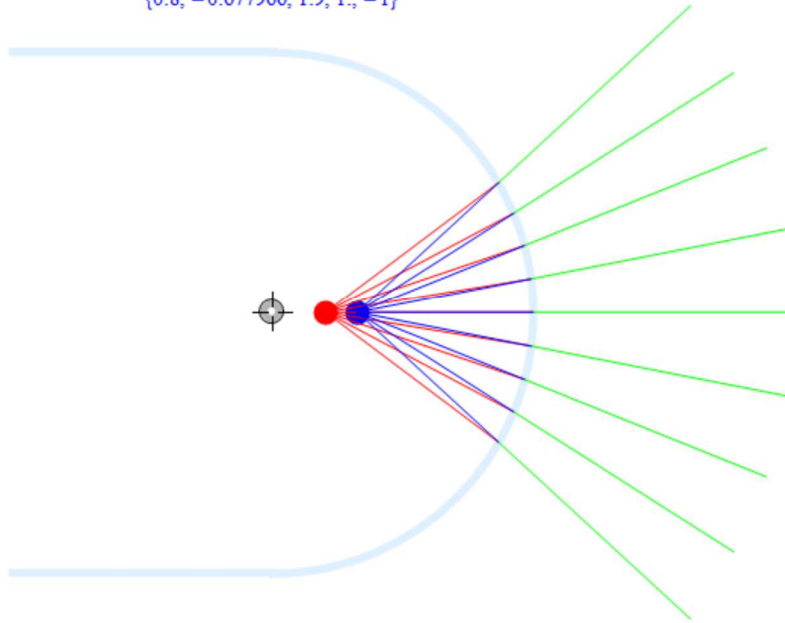

(ii) $p = 1.5$ and $q = -2.72727$

$\{p, q, n1, n2, R\} =$
 $\{1.5, -2.72727, 1.9, 1., -1\}$

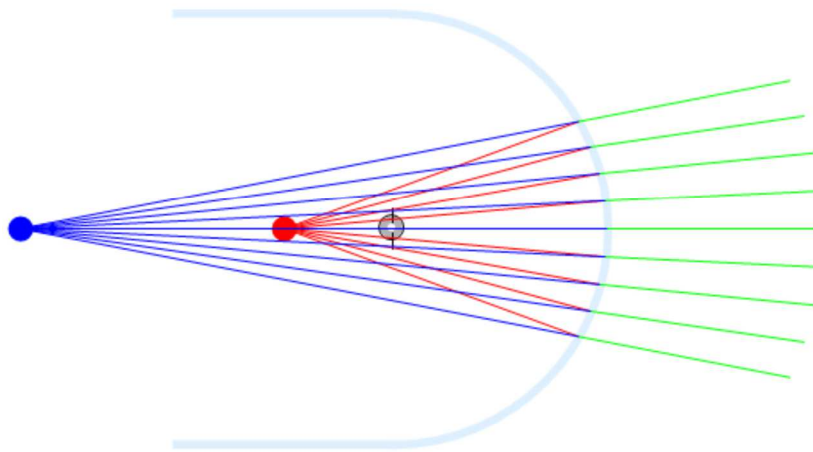

(iii) $p = 5.0$ and $q = 1.92308$

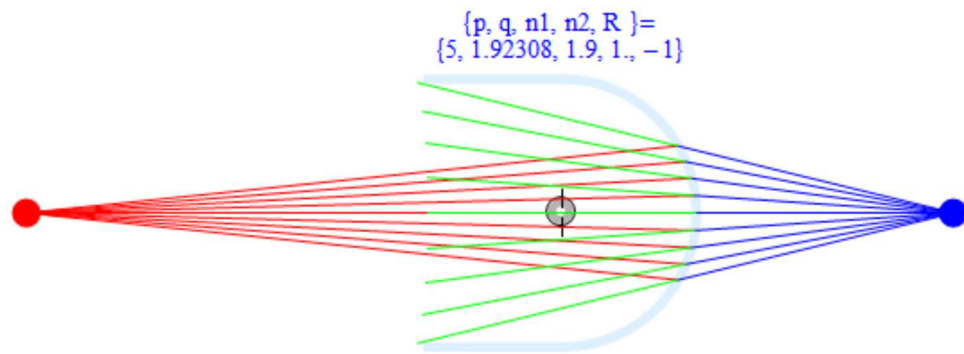

(c) $n_1 = 1.9, n_2 = 1.0, R = 1.0$

(i) $p = 0.5$ and $q = -0.21277$

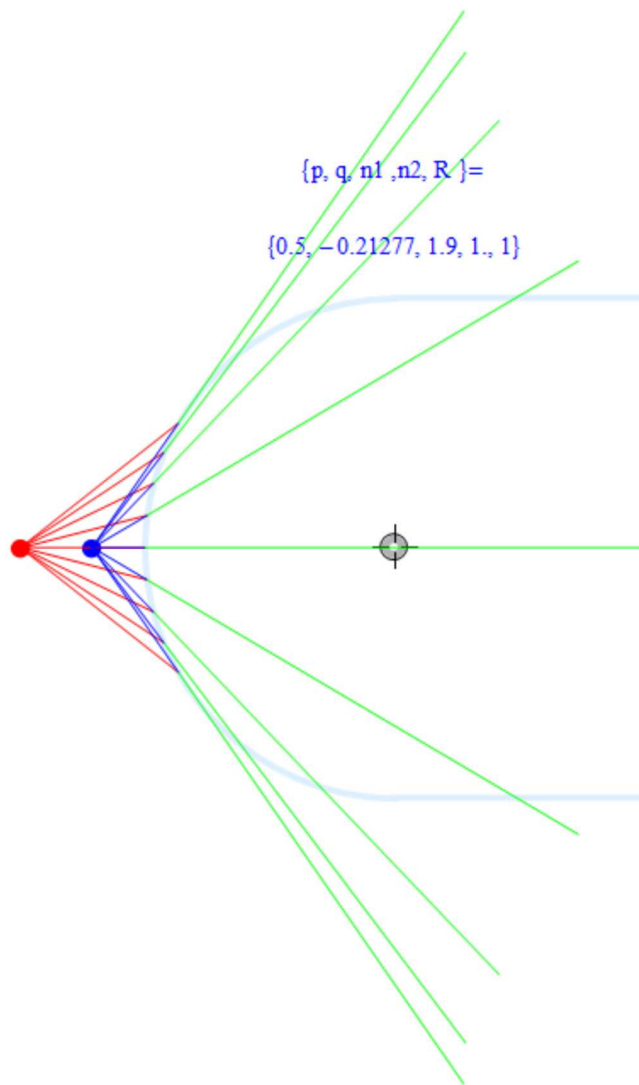

(ii) $p = 2.0$ and $q = -0.54505$

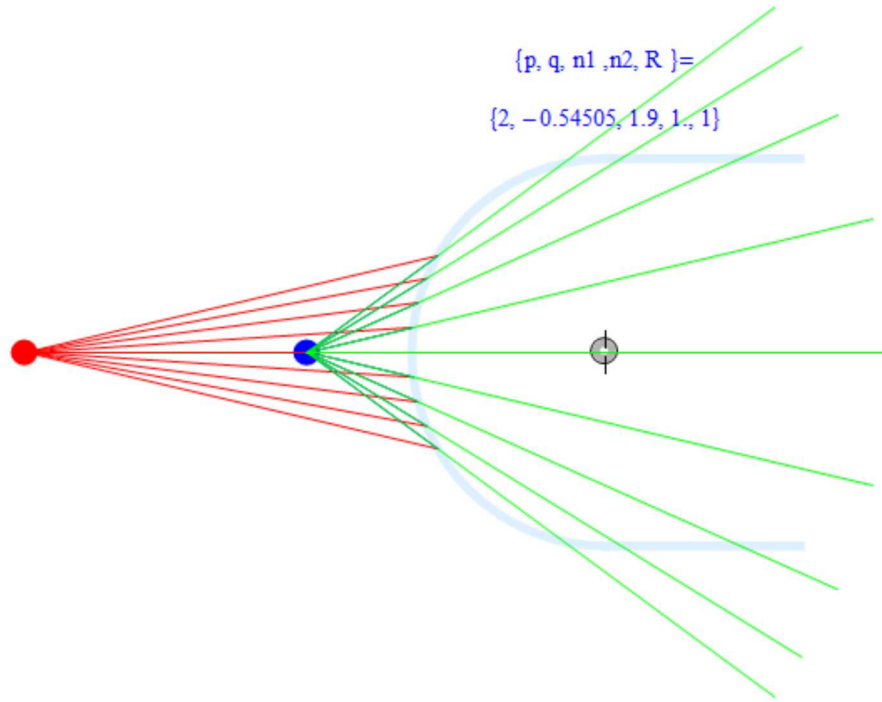

(d) $n_1 = 1.0, n_2 = 1.9, R = -1.0$

(i) $p = 0.5$ and $q = -0.655172$

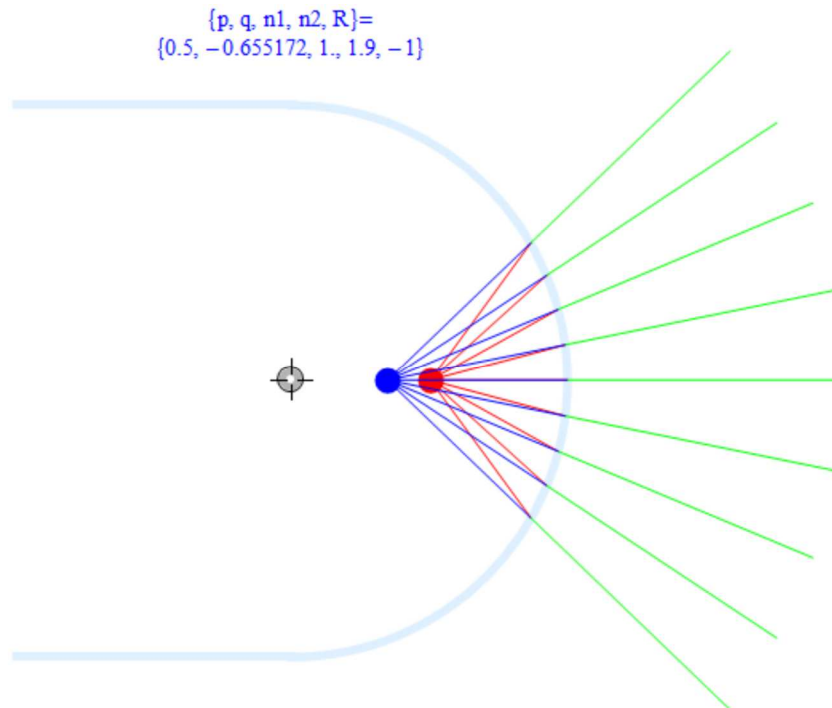

(ii) $p = 0.8$ and $q = -0.883721$

$\{p, q, n1, n2, R\} =$
 $\{0.8, -0.883721, 1, 1.9, -1\}$

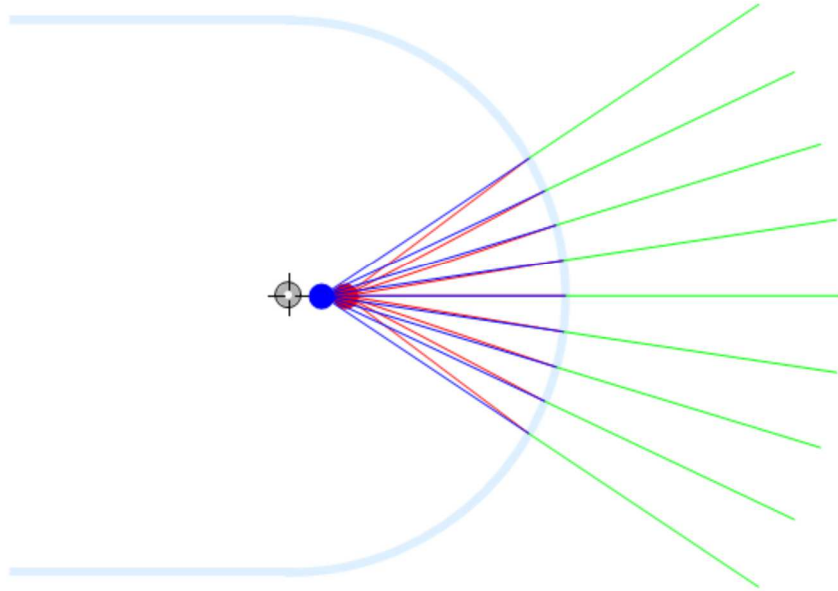

4.2 Determining signs

Spherical surface refraction

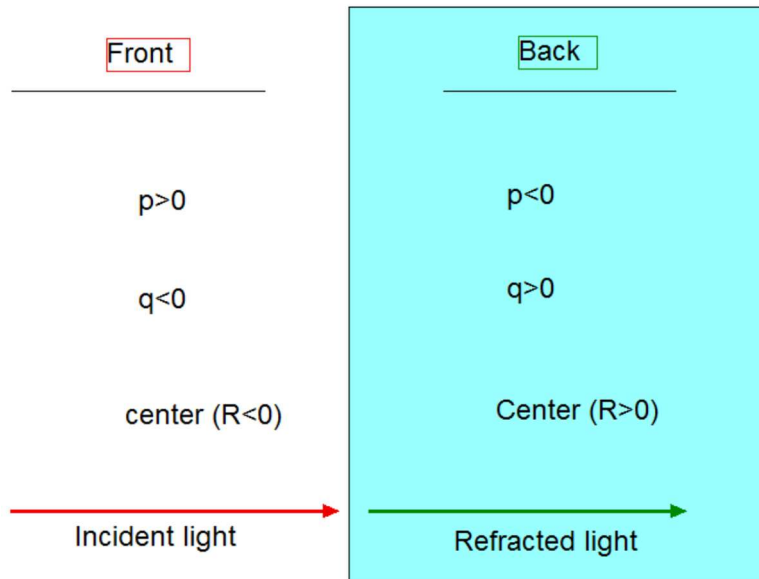

- (1) The front side of the thin lens is the side of the incident light.
- (2) The back side of the lens is where the light is refracted into.
- (3) This is also valid for a thin lens.

Object	Positive when....	Negative when ...
Object location (p)	front of surface (real)	back of surface (virtual)
Image location (q)	back of surface (real)	front of surface (virtual)
Image height (h')	upright	inverted
Radius (R)	center (back of surface)	center (front of surface)

4.3. Flat refracting surfaces

If a refracting surface is flat, R is infinite. Then

$$q = -\frac{n_2}{n_1} p.$$

The image formed by a flat refracting surface is on the same side of the surface as the object. A virtual image is formed

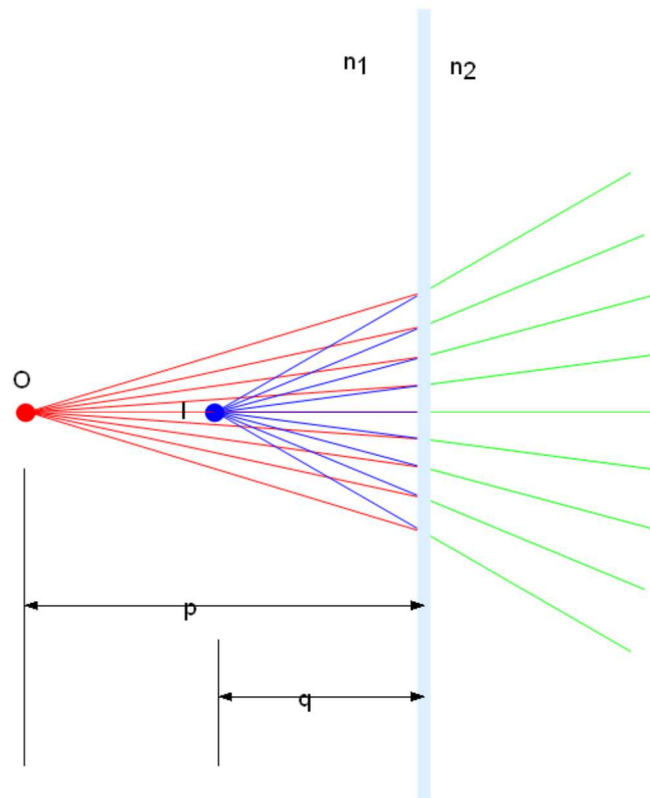
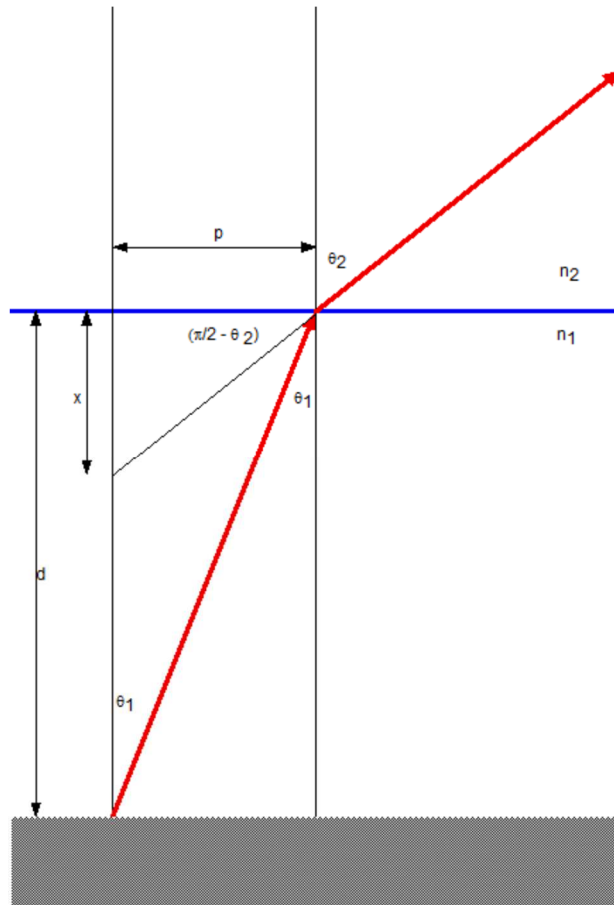

Fig. $n_1 = 1.9$ and $n_2 = 1$. $R = \infty$

This problem can be solved in a different way. We assume that $n_1 > n_2$.



Snell's law:

$$n_2 \sin \theta_2 = n_1 \sin \theta_1$$

In the limit of small angles,

$$\frac{\theta_2}{\theta_1} = \frac{n_1}{n_2} > 1$$

From the geometry,

$$x = p \tan\left(\frac{\pi}{2} - \theta_2\right) = p \cot \theta_2$$

$$p = d \tan \theta_1$$

or

$$x = d \tan \theta_1 \cot \theta_2 = d \frac{\tan \theta_1}{\tan \theta_2} \approx d \frac{\theta_1}{\theta_2} = d \frac{n_2}{n_1} < d$$

4.4 Derivation of the formula

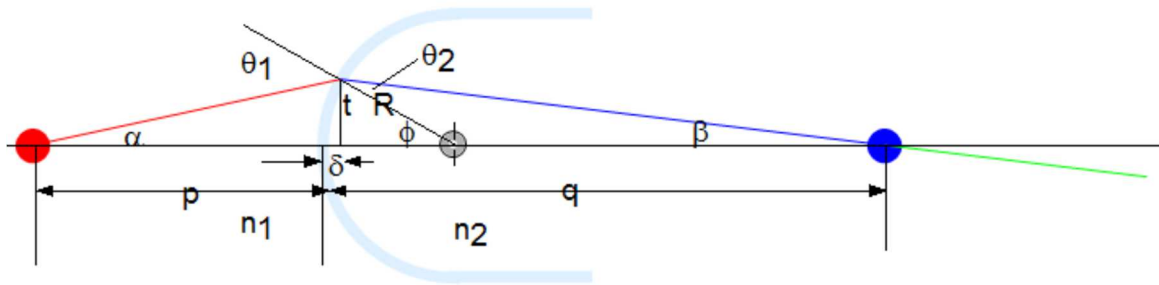

From the geometry, we have

$$\theta_1 = \alpha + \phi$$

$$\phi = \beta + \theta_2$$

From the law of refraction,

$$n_1 \sin \theta_1 = n_2 \sin \theta_2$$

The tangents of α , β , and ϕ are

$$\tan \alpha = \frac{t}{p + \delta}$$

$$\tan \beta = \frac{t}{q - \delta}$$

$$\tan \phi = \frac{t}{R - \delta}$$

Paraxial rays, we may approximate both sine and tangent of the angles by the angles itself (measured in radians).

$$n_1 \theta_1 = n_2 \theta_2$$

or

$$n_1 (\alpha + \phi) = n_2 (\phi - \beta)$$

or

$$n_1\alpha + n_2\beta = (n_2 - n_1)\phi$$

We use the approximation

$$\alpha = \frac{t}{p}$$

$$\beta = \frac{t}{q}$$

$$\phi = \frac{t}{R}$$

Then we have the object-image relationship for spherical refracting surface.

$$\frac{n_1}{p} + \frac{n_2}{q} = \frac{(n_2 - n_1)}{R}$$

4.5 Lateral magnification

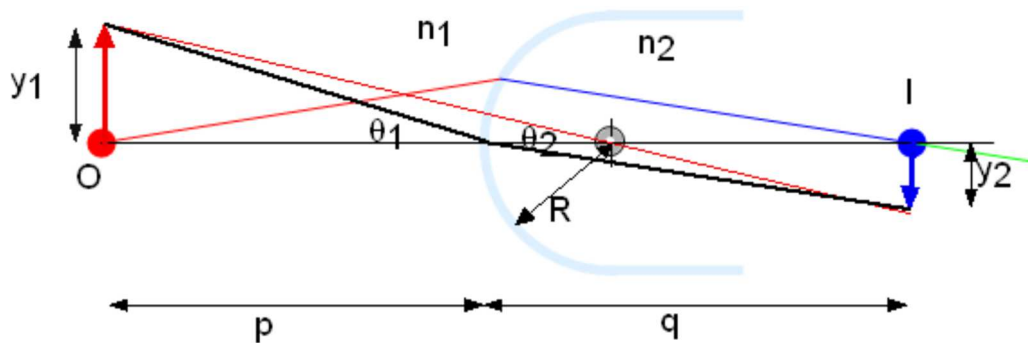

Fig. Spherical surface refraction. $n_2 > n_1$ for this figure.

In order to obtain the lateral magnification, we use the construction shown above.

$$\tan \theta_1 = \frac{y_1}{p} \approx \theta_1$$

$$\tan \theta_2 = -\frac{y_2}{q} \approx \theta_2$$

Using the Snell's law given by

$$n_1\theta_1 = n_2\theta_2$$

we have the lateral magnification m

$$m = \frac{y_2}{y_1} = -\frac{q\theta_2}{p\theta_1} = -\frac{qn_1}{pn_2} = -\frac{\frac{q}{n_2}}{\frac{p}{n_1}}$$

5. Lens

A typical thin lens consists of a piece of glass or plastic. It is ground so that the two surfaces are either segments of spheres or planes. The thin lens approximation assumes the thickness of the lens to be negligible. So the focal point can be measured to the center or the surface of the lens. Lenses will have one focal length and two focal points.

5.1 Thin Lens Shapes

(1) The converging lenses

They have positive focal lengths. They are thickest in the middle

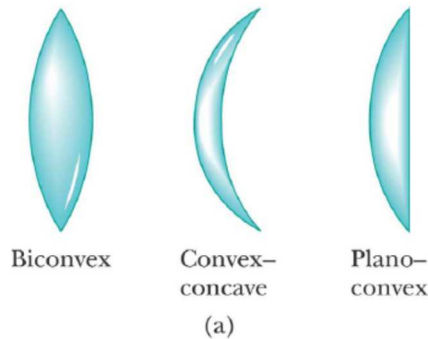

(2) The diverging lenses

They have negative focal lengths. They are thickest at the edges

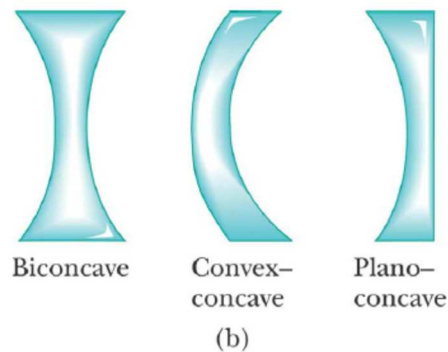

5.2 Focal Length of a converging lens

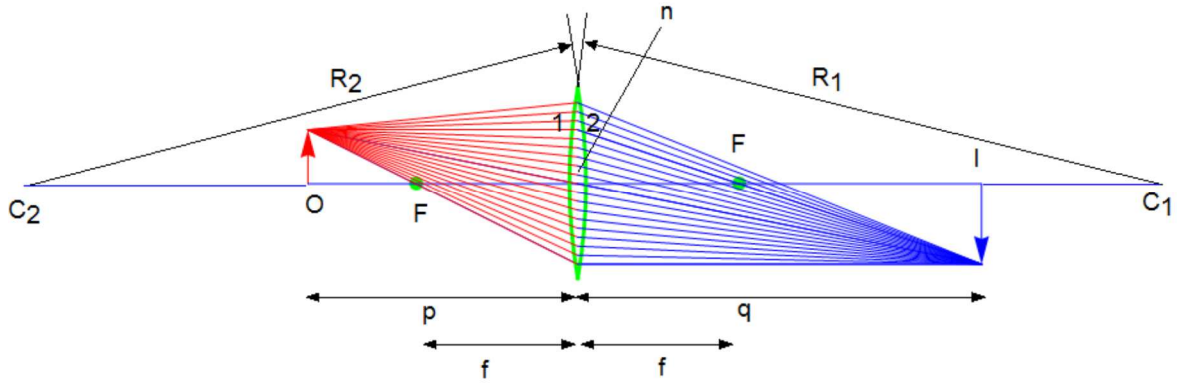

- (1) The parallel rays pass through the lens and converge at the focal point.
- (2) The parallel rays can come from the left or right of the lens.
- (3) The focal points are the same distance from the lens.

5.3 Focal length of a diverging lens

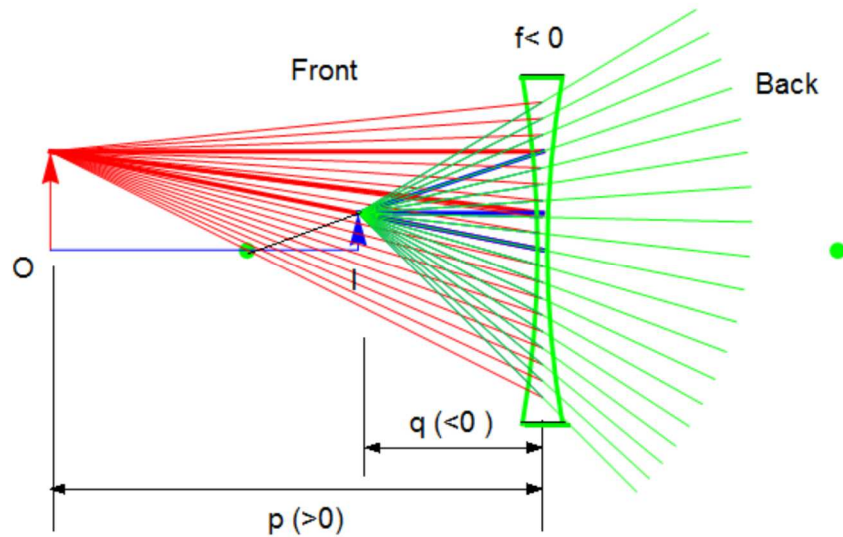

- (1) The parallel rays pass through the lens and converge at the focal point.
- (2) The parallel rays can come from the left or right of the lens.
- (3) The focal points are the same distance from the lens.

5.4 Image formed by a thin lens

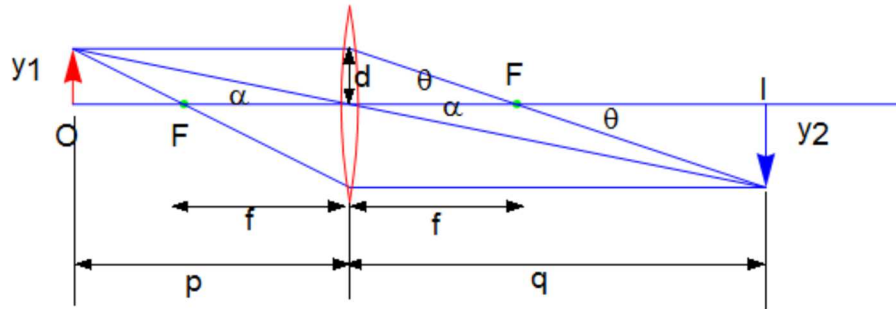

Fig. y_1 and y_2 are the y -co-ordinates of the object and the image, respectively.

From this geometry, we have

$$y_1 = p \tan \alpha \approx p\alpha$$

$$y_1 = d = f \tan \theta \approx f\theta$$

$$|y_2| = q \tan \alpha \approx q\alpha$$

$$|y_2| = (q - f) \tan \theta \approx (q - f)\theta$$

From these equations,

$$p\alpha = f\theta$$

$$q\alpha = (q - f)\theta$$

or

$$(q - f)p = fq$$

or

$$\frac{1}{p} + \frac{1}{q} = \frac{1}{f}$$

5.5 Magnification of images through a thin Lens

The lateral magnification of the image is

$$m = \frac{y_2}{y_1} = -\frac{q}{p}$$

When m is positive, the image is upright and on the same side of the lens as the object. When m is negative, the image is inverted and on the side of the lens opposite the object.

5.6 Determining signs for thin lenses

Lens

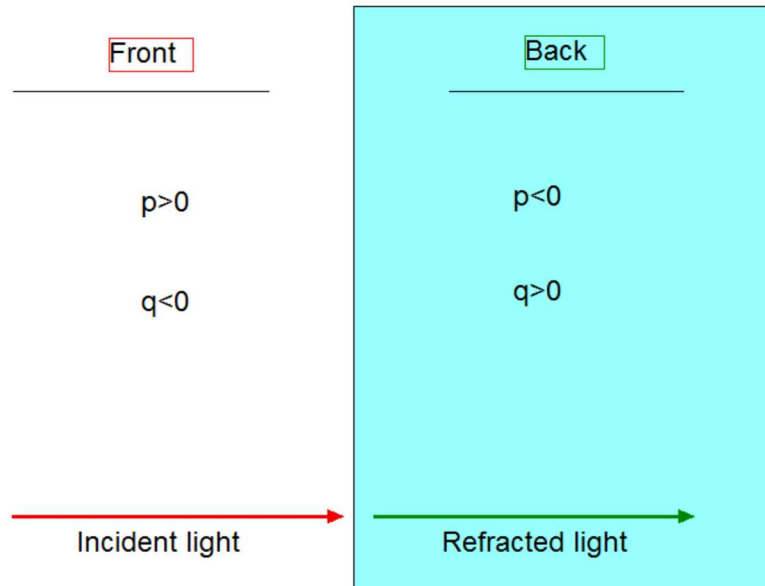

- (1) The front side of the thin lens is the side of the incident light
- (2) The back side of the lens is where the light is refracted into.
- (3) This is also valid for a refracting surface

5.7 Notes on focal length and focal point of a thin lens

- (1) A converging lens has a positive focal length. Therefore, it is sometimes called a positive lens
- (2) A diverging lens has a negative focal length. It is sometimes called a negative lens

5.8 Lens makers' equation

The focal length of a thin lens is the image distance that corresponds to an infinite object distance. This is the same as for a mirror. The focal length is related to the radii of curvature of the surfaces and to the index of refraction of the material

The lens makers' equation is

$$\frac{1}{f} = (n-1)\left(\frac{1}{R_1} - \frac{1}{R_2}\right)$$

where R_1 is the radius of curvature of the lens surface near the object, and R_2 is that of the other surface. $R > 0$ when the center of curvature is on the outgoing side of the surface. $R < 0$ otherwise.

((The proof of the lens maker's equation))

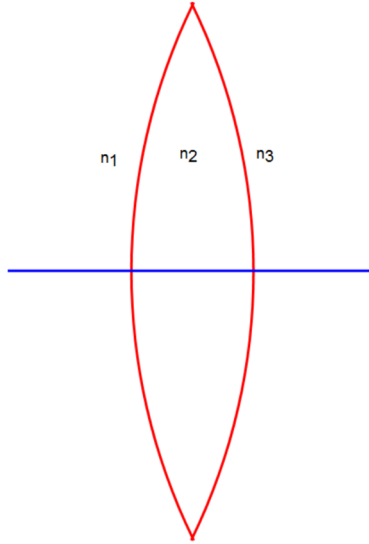

We use the equation for the spherical surface refraction twice, for $n_1 (= 1)$ and $n_2 (= n)$ and for $n_2 (= n)$ and $n_3 (= 1)$.

$$\frac{n_1}{p} + \frac{n_2}{q_1} = \frac{(n_2 - n_1)}{R_1}$$

$$\frac{n_2}{p_2} + \frac{n_3}{q} = \frac{(n_3 - n_2)}{R_2}$$

Here we put $p_2 + q_1 = 0$ (in the limit of thin lens)

or

$$p_2 = -q_1$$

From the addition of two equations, we get

$$\frac{n_1}{p} + \frac{n_3}{q} = \frac{(n_2 - n_1)}{R_1} + \frac{(n_3 - n_2)}{R_2}$$

For $n_1 = n_3 = 1$ and $n_2 = n$,

$$\frac{1}{p} + \frac{1}{q} = \frac{1}{f}$$

with

$$\frac{1}{f} = (n-1)\left(\frac{1}{R_1} - \frac{1}{R_2}\right) \quad (\text{lens maker's equation for a thin lens})$$

5.9 Sign conventions for thin lenses

Object	Positive when....	Negative when ...
Object location (p)	in front of lens (real)	back of lens (virtual)
Image location (q)	in back of lens (real)	front of lens (virtual)
Image height (h')	upright	inverted
Focal length (f)	converging lens	diverging
Magnification (m)	upright	inverted
R_1 and R_2	center (in back)	Center (front)

5.10 Longitudinal magnification

The longitudinal magnification is defined as

$$m_L = \frac{dq}{dp}$$

This is the ratio of an infinitesimal axial length in the region of the image to the corresponding length in the region of the object. Differentiating the equation given by

$$\frac{1}{p} + \frac{1}{q} = \frac{1}{f}$$

we have

$$m_L = \frac{dq}{dp} = -\frac{q^2}{p^2} = -m_T^2$$

5.11 Ray Diagrams for thin lenses – converging

Ray diagrams are convenient for locating the images formed by thin lenses or systems of lenses

For a converging lens, the following three rays are drawn.

- (i) Ray 1 is drawn parallel to the principal axis and then passes through the focal point on the back side of the lens.
- (ii) Ray 2 is drawn through the center of the lens and continues in a straight line.

- (iii) Ray 3 is drawn through the focal point on the front of the lens (or as if coming from the focal point if $p < f$) and emerges from the lens parallel to the principal axis.

5.11.1 Ray diagram for converging lens, $p > f$

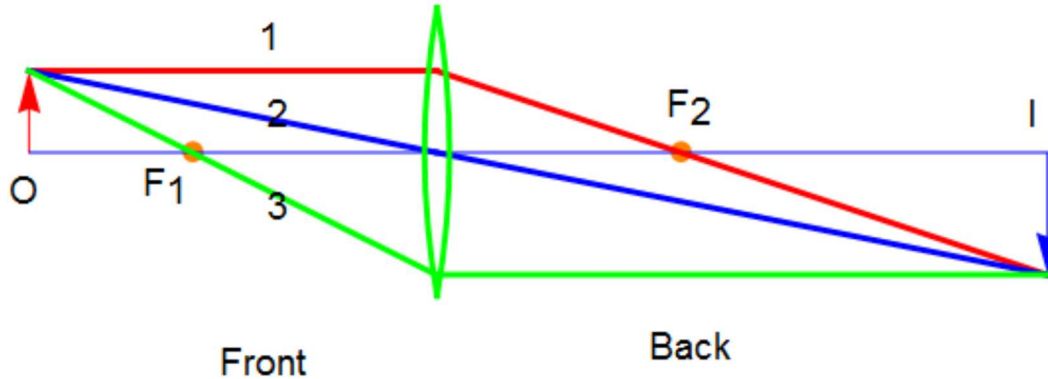

- (1) The image is real ($q > 0$)
- (2) The image is inverted ($m < 0$)
- (3) The image is on the back side of the lens.

5.11.2 Ray Diagram for converging lens, $p < f$

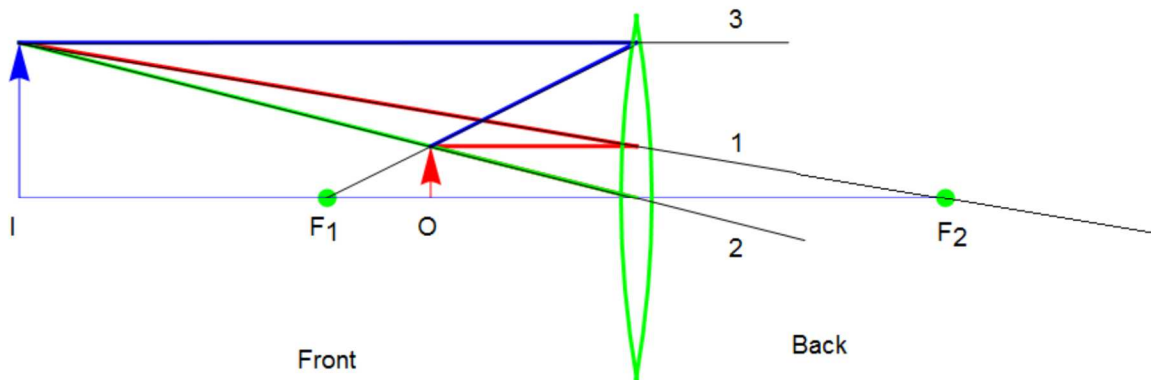

- (1) The image is virtual ($q < 0$)
- (2) The image is upright ($m > 0$)
- (3) The image is larger than the object.
- (4) The image is on the front side of the lens.

5.12 Ray Diagrams for thin lenses – diverging

For a diverging lens, the following three rays are drawn.

- (1) Ray 1 is drawn parallel to the principal axis and emerges directed away from the focal point on the front side of the lens.
- (2) Ray 2 is drawn through the center of the lens and continues in a straight line.

- (3) Ray 3 is drawn in the direction toward the focal point on the back side of the lens and emerges from the lens parallel to the principal axis.

Ray diagram for diverging lens (hold for both $p > f$ and $p < f$)

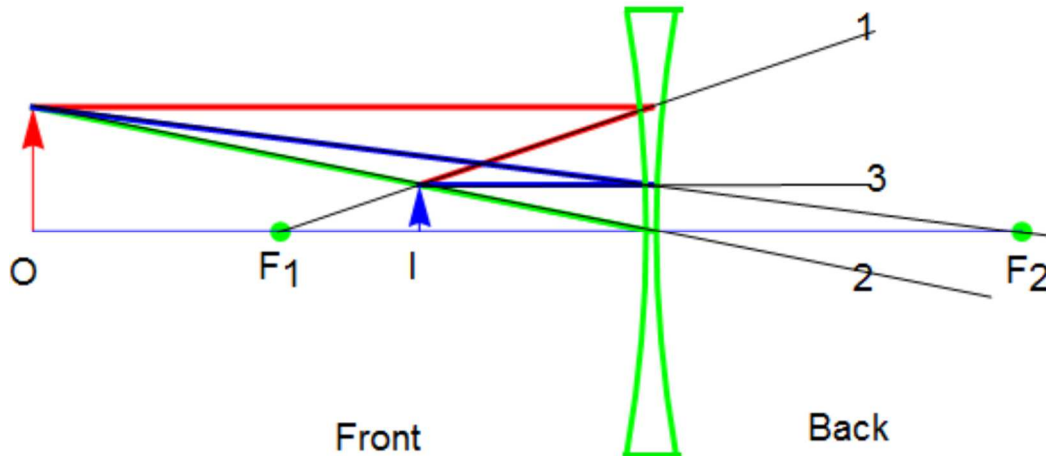

- (i) The image is virtual ($q < 0$)
- (ii) The image is upright ($m > 0$)
- (iii) The image is smaller.
- (iv) The image is on the front side of the lens.

5.13 Drawing of the ray diagram using using Mathematica

Using the Mathematica program (Graphics), we make the ray diagram of the converging lens and diverging lens in various configurations.

5.13.1 Converging lens (typical examples)

The red arrow denotes a image and the blue arrow denotes a image.

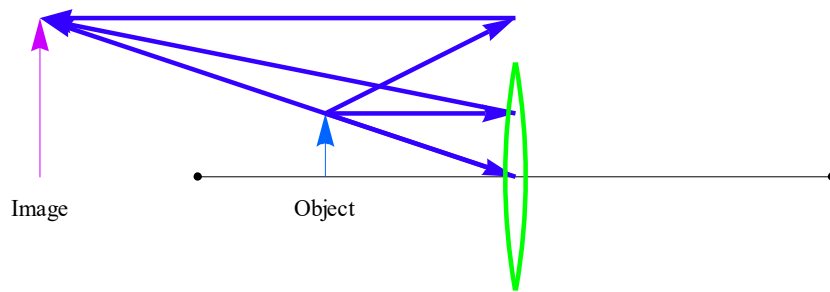
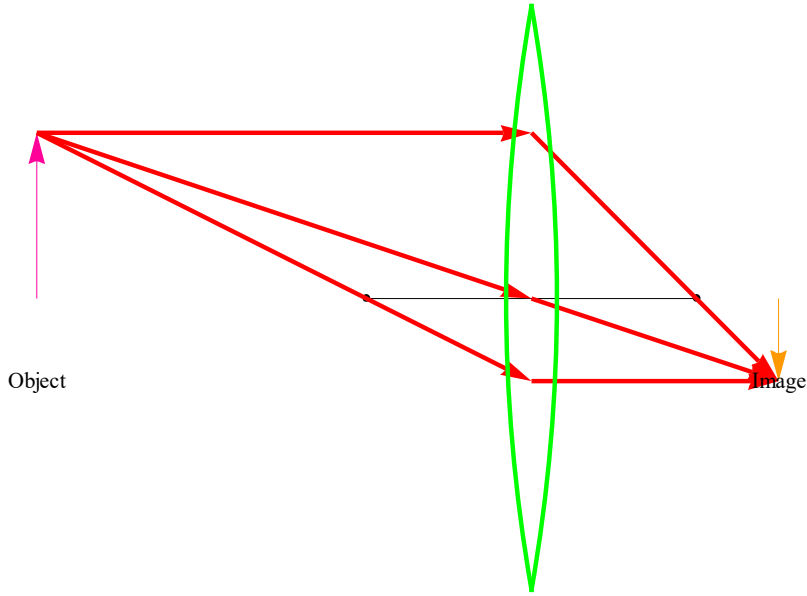

5.13.2 Diverging lens (typical examples)

The red arrow denotes a object and the blue arrow denotes a image.

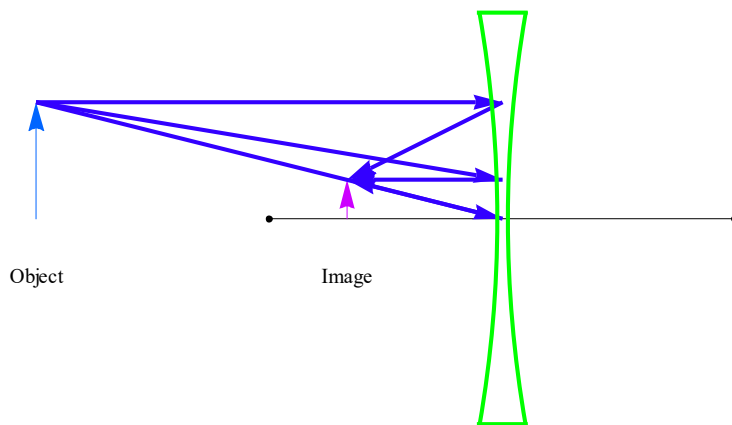

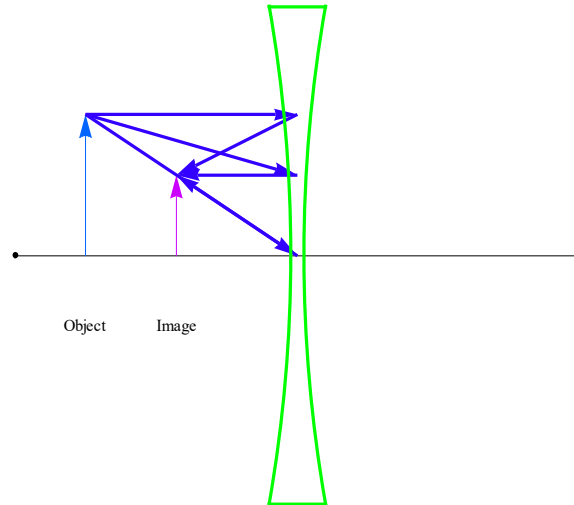

.14 Image Summary

- (i) For a converging lens, when the object distance is greater than the focal length ($p > f$). The image is real and inverted.
- (ii) For a converging lens, when the object is between the focal point and the lens, ($p < f$). The image is virtual and upright.
- (iii) For a diverging lens, the image is always virtual and upright. This is regardless of where the object is placed.

5. Combination of thin lenses

The image formed by the first lens is located as though the second lens were not present. Then rays or calculations are completed for the second lens. The image of the first lens is treated as the object of the second lens. The image formed by the second lens is the final image of the system. If the image formed by the first lens lies on the back side of the second lens, then the image is treated as a virtual object for the second lens.

p will be negative. The same procedure can be extended to a system of three or more lenses. The overall magnification is the product of the magnification of the separate lenses

((Example))

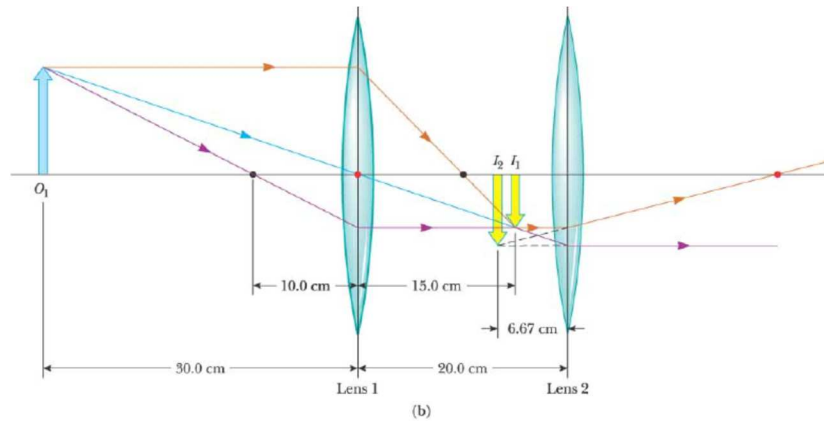

For the converging lens-1

$$\frac{1}{p_1} + \frac{1}{q_1} = \frac{1}{f_1}, \quad \text{with } f_1 = 10 \text{ cm and } p_1 = 30 \text{ cm.}$$

or

$$\frac{1}{30} + \frac{1}{q_1} = \frac{1}{10} \quad \text{with } q_1 = 15 \text{ cm}$$

The lateral magnification m_1 is

$$m_1 = -\frac{q_1}{p_1} = -\frac{15}{30} = -\frac{1}{2}$$

For the converging lens-2

$$\frac{1}{p_2} + \frac{1}{q_2} = \frac{1}{f_2}, \quad \text{with } f_2 = 20 \text{ cm and } p_2 = (20-15) = 5 \text{ cm.}$$

or

$$\frac{1}{5} + \frac{1}{q_2} = \frac{1}{20} \quad \text{with } q_2 = -6.67 \text{ cm}$$

The lateral magnification m_2 is

$$m_2 = -\frac{q_2}{p_2} = \frac{6.67}{5} = 1.33$$

The resultant magnification is

$$m = m_1 m_2 = \left(-\frac{1}{2}\right)1.33 = -0.667 \quad (\text{inverted})$$

7. Mathematica diagrams for the construction of the ray diagram

The ray diagram of the combination of two lenses separated by some distance can be derived using the Mathematica program

7.1 Combination of two converging lenses

d_1 is the separation distance between the lens 1 and lens 2.

h_1 is the height of the object

((**Example-1**)) This is similar to the above example.

Converging lens ($f_1 = 1$ cm) and converging lens ($f_2 = 2$ cm)

$p_1 = 3$ cm, $h_1 = 1.5$ cm, and $d = 2$ cm

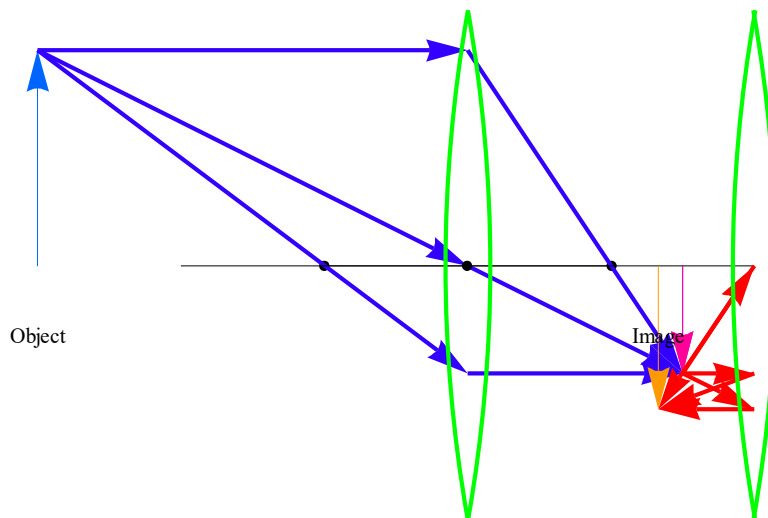

((**Example-2**))

Converging lens ($f_1 = 1$ cm) and converging lens ($f_2 = 2$ cm)

$p_1 = 3$ cm, $h_1 = 1$ cm, and $d_1 = 5$ cm.

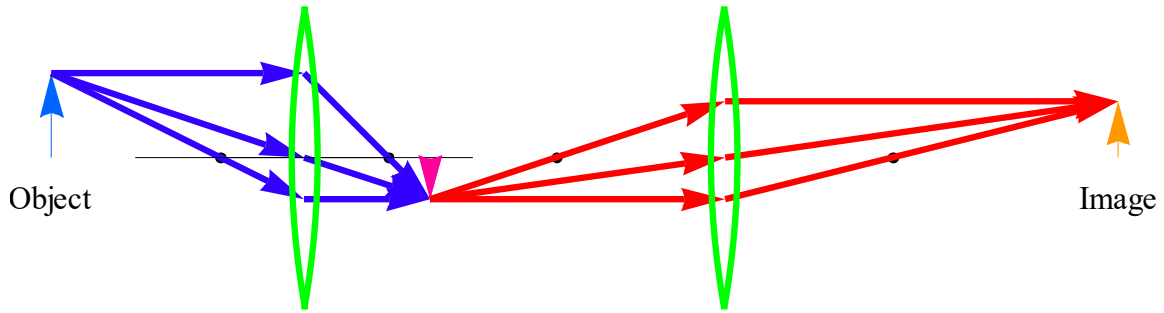

(Example-3)

Converging lens ($f_1 = 1.5$ cm) and converging lens ($f_2 = 1.5$ cm)
 $p_1 = 1$ cm, $h_1 = 0.5$ cm, and $d_1 = 0.6$ cm.

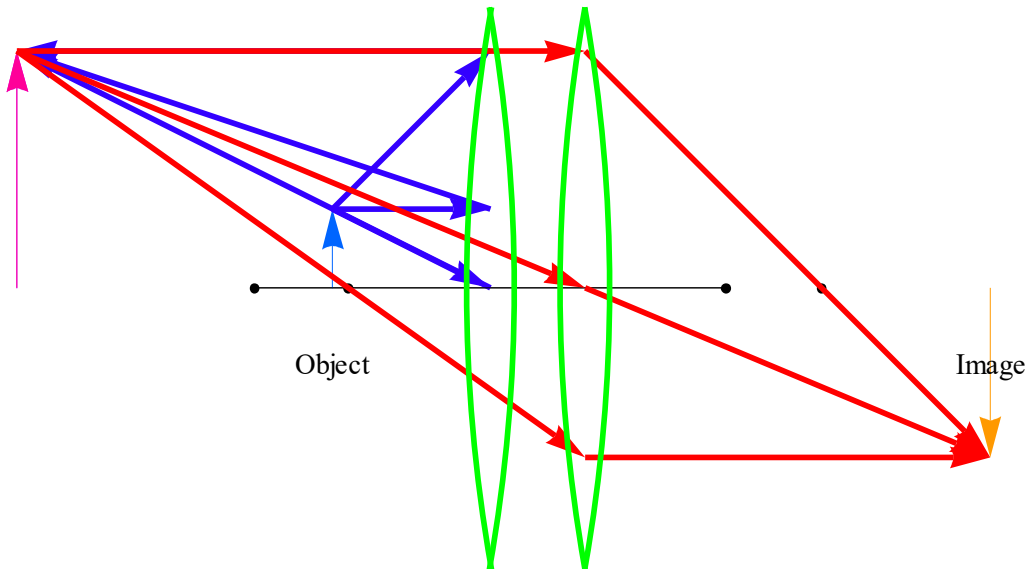

(Example-4)

Converging lens ($f_1 = 2.0$ cm) and converging lens ($f_2 = 4.5$ cm)
 $p_1 = 5.0$ cm, $h_1 = 0.35$ cm, and $d_1 = 6.5$ cm.

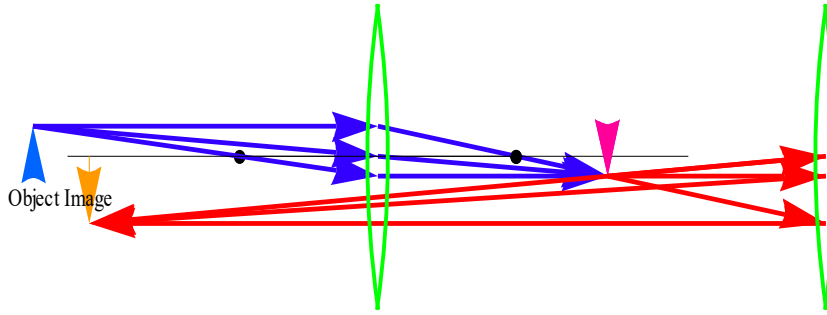

7.2 Combination of one converging lens and one diverging lens

((Example-1))

Converging lens ($f_1 = 1.0$ cm) and diverging lens ($f_2 = -2.0$ cm)
 $p_1 = 3$ cm, $h_1 = 1.8$ cm, and $d_1 = 5.0$ cm.

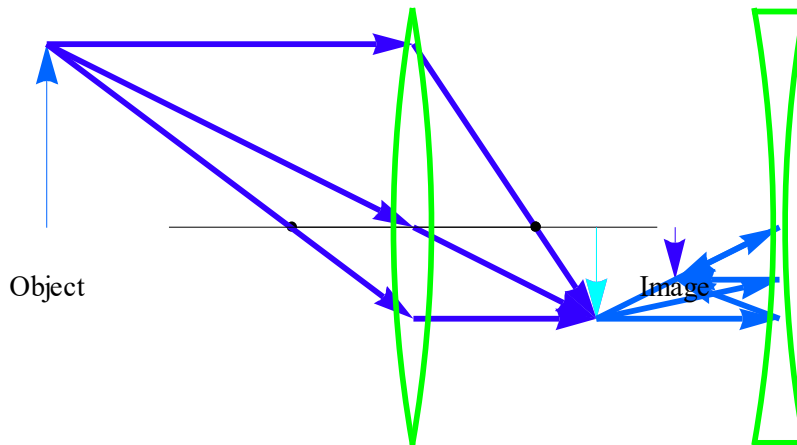

((Example-2))

Converging lens ($f_1 = 1.0$ cm) and diverging lens ($f_2 = -2.0$ cm)
 $p_1 = 3$ cm, $h_1 = 1.5$ cm, and $d_1 = 1.0$ cm.

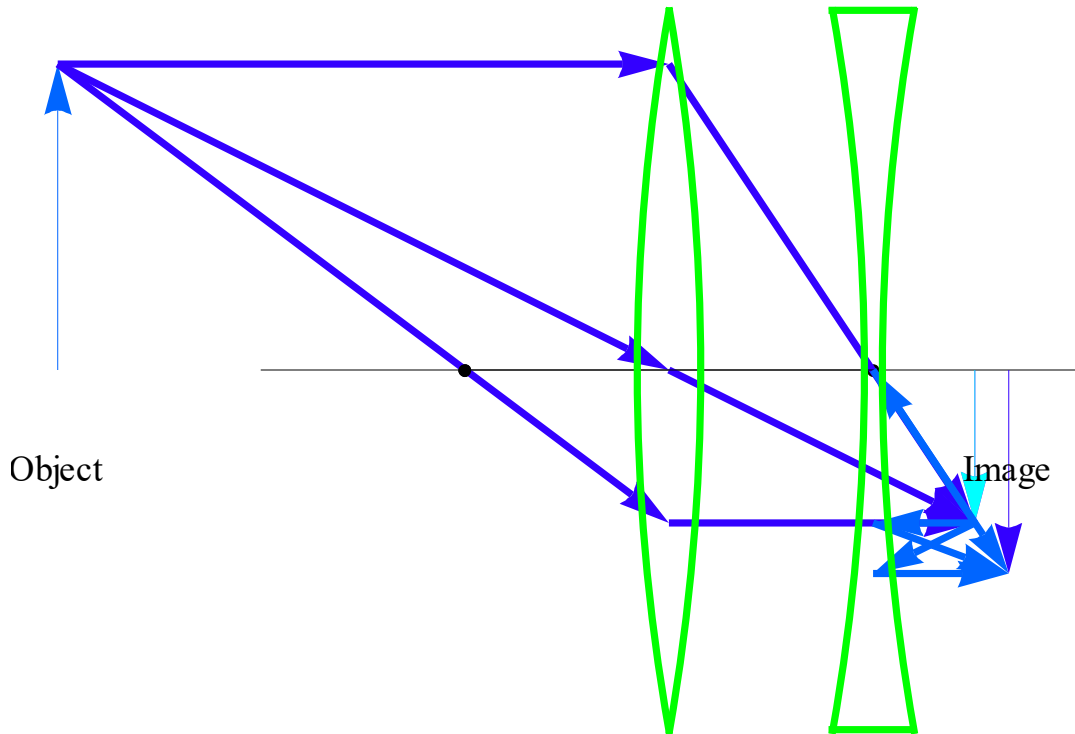

(Example-3)

Converging lens ($f_1 = 1.0$ cm) and diverging lens ($f_2 = -3.0$ cm)
 $p_1 = 0.5$ cm, $h_1 = 0.5$ cm, and $d_1 = 2.0$ cm.

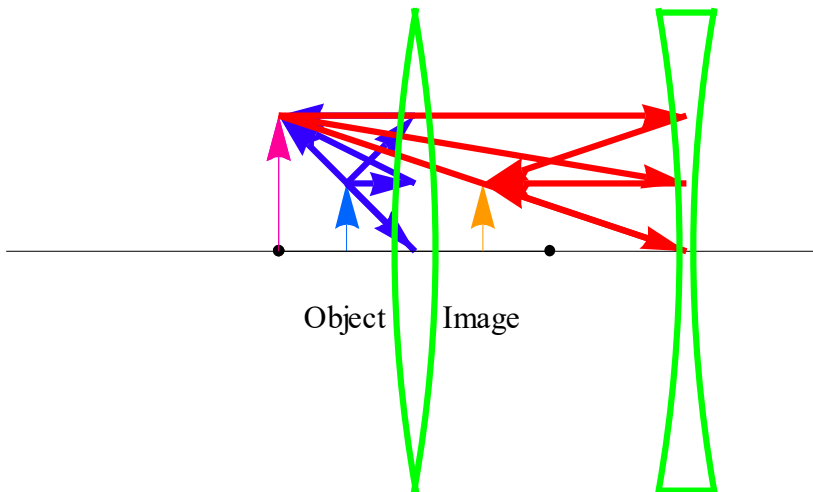

(Example-4)

Converging lens ($f_1 = 1.2$ cm) and diverging lens ($f_2 = -3.2$ cm)
 $p_1 = 1.8$ cm, $h_1 = 0.5$ cm, and $d_1 = 2.2$ cm.

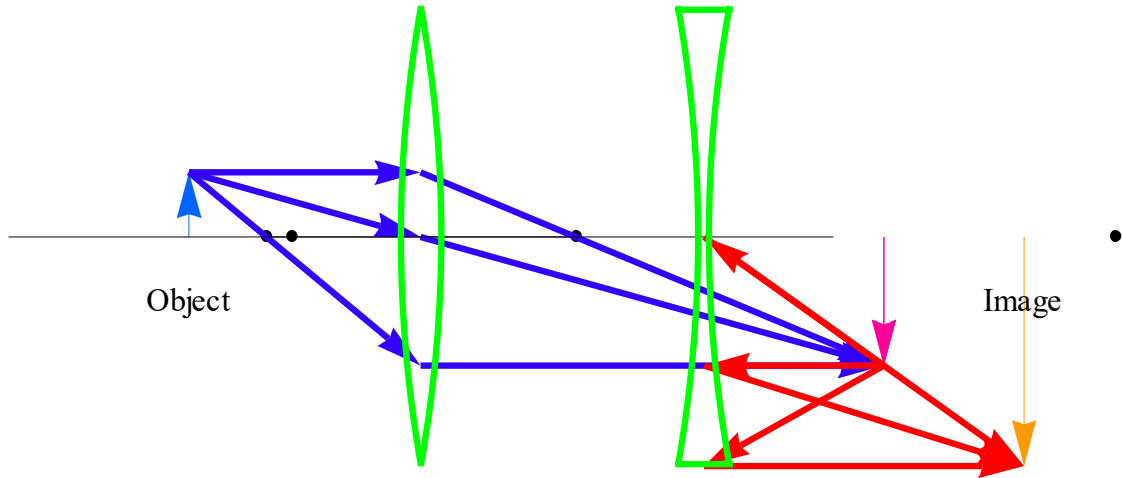

7.3 Combination of two diverging lenses

((Example-1))

diverging lens ($f_1 = -1.0$ cm) and diverging lens ($f_2 = -1.0$ cm)
 $p_1 = 0.5$ cm, $h_1 = 1.5$ cm, and $d_1 = 3.0$ cm.

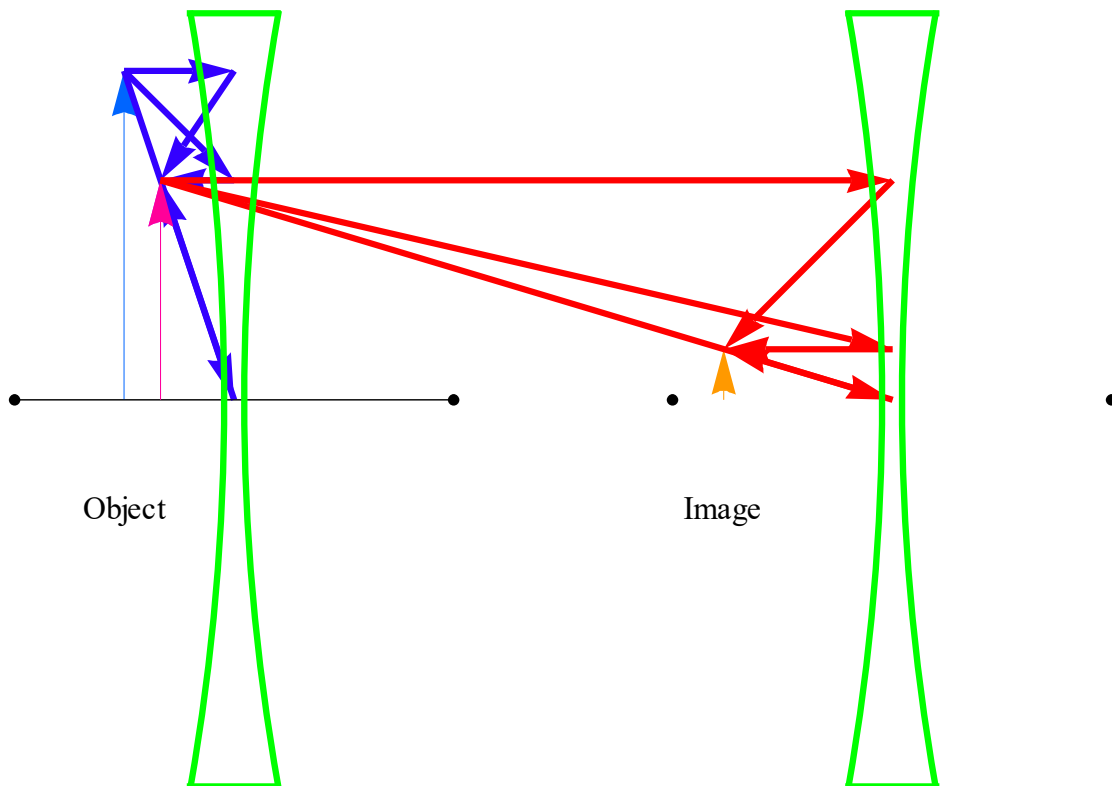

((Example-2))

diverging lens ($f_1 = -1.0$ cm) and diverging lens ($f_2 = -2.0$ cm)

$p_1 = 3.0 \text{ cm}$, $h_1 = 1.0 \text{ cm}$, and $d_1 = 8.5 \text{ cm}$.

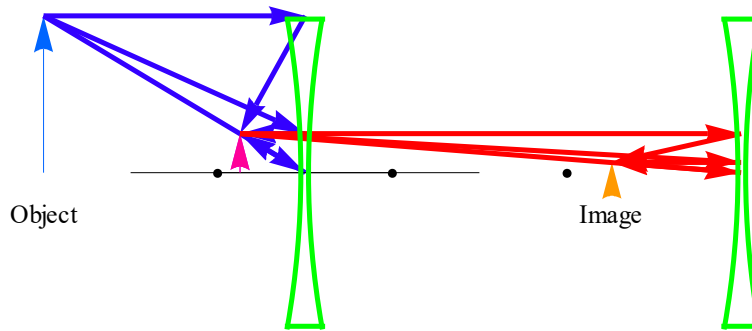

7.4 Combination of three lenses

d_1 is the separation distance between the lens 1 and lens 2.

d_2 is the separation distance between the lens 2 and lens 3.

h_1 is the height of the object

((Example-1))

Three converging lenses ($f_1 = f_2 = f_3 = 1.0 \text{ cm}$)

$p_1 = 1.8 \text{ cm}$, $h_1 = 1.0 \text{ cm}$, $d_1 = 3.0 \text{ cm}$, $d_2 = 2.0 \text{ cm}$

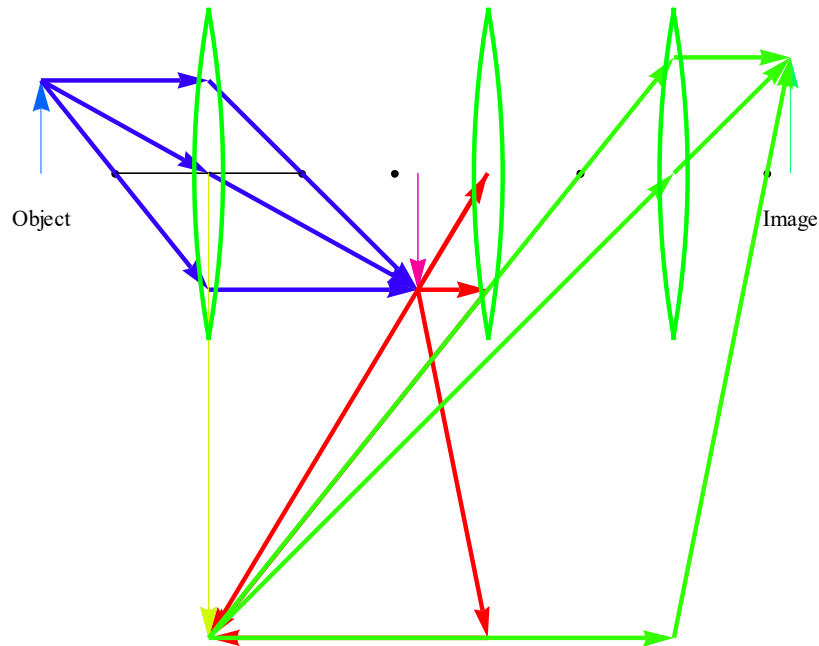

((Example-2))

Three lenses ($f_1 = f_3 = 1.0 \text{ cm}$, $f_2 = -1.0 \text{ cm}$)

$p_1 = 1.8 \text{ cm}$, $h_1 = 1.0 \text{ cm}$, $d_1 = 3.0 \text{ cm}$, $d_2 = 2.0 \text{ cm}$

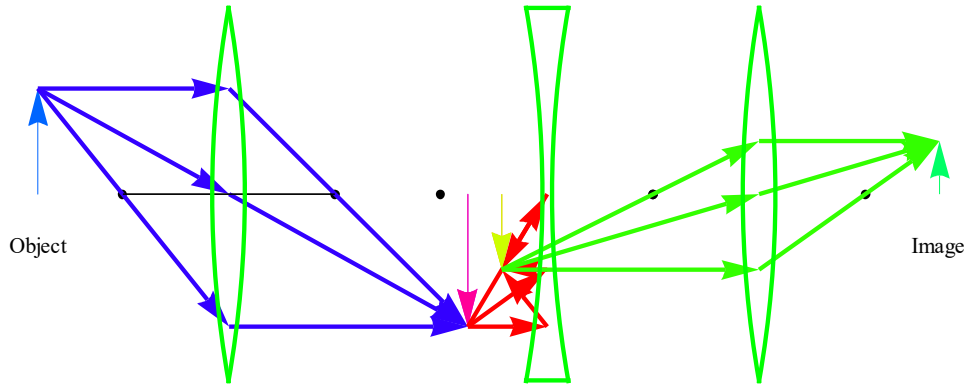

8. Optical instrument

8.1 Simple magnifier

The normal human eye can focus a sharp image of an object on the retina (at the rear of the eye) if the object is located anywhere from infinity to a certain point called the **near point** P_n . If you move the object closer to the eye than the near point, the perceived retinal image becomes fuzzy. To find your own near point, remove your glasses or contacts if you wear any, close one eye, and then bring this page closer to your open eye until it becomes indistinct.

In what follows, we take the near point to be **25 cm** from the eye, a bit more than the typical value for 20-year-olds.

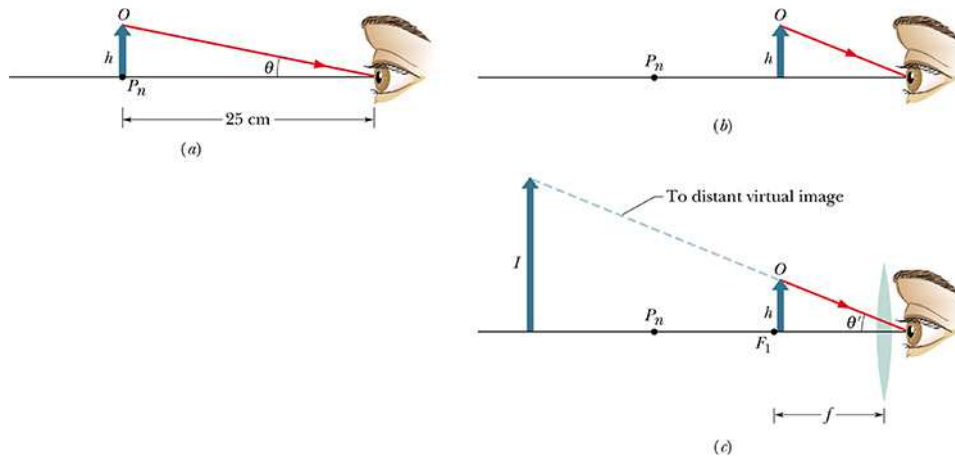

Fig.1

- (a) An object O of height h placed at the near point of a human eye occupies angle θ in the eye's view.

$$\tan \theta = \frac{h}{25\text{cm}} \approx \theta$$

- (b) The object is moved closer to increase the angle, but now the observer cannot bring the object into focus.

- (c) A converging lens is placed between the object and the eye, *with the object just inside the focal point F_1 of the lens*. The image produced by the lens is then far enough away to be focused by the eye, and the image occupies a larger angle θ' than object O does in (a).

For the converging lens,

$$\frac{1}{f} = \frac{1}{p} + \frac{1}{q}$$

with $p = f - \delta$ ($\delta \rightarrow +0$). So we have

$$\frac{1}{q} = \frac{1}{f} - \frac{1}{f - \delta} = \frac{-\delta}{f(f - \delta)} \approx -\frac{\delta}{f^2}.$$

When $\delta \rightarrow +0$, we have $q \rightarrow (-\infty)$ (virtual image).

$$\tan \theta' = \frac{h}{f} \approx \theta'$$

The *angular magnification* m_θ (not to be confused with lateral magnification m) of what is seen is

$$m_\theta = \frac{\theta'}{\theta} = \frac{h/f}{h/25\text{cm}} = \frac{25\text{cm}}{f}$$

8.2 Refracting telescope

This is used for viewing *very distant objects* (for example, stars or ships on the horizon). The instrument consists of an objective (the front lens) of focal length f_1 and an eyepiece (the lens near the eye) of focal length f_2 .

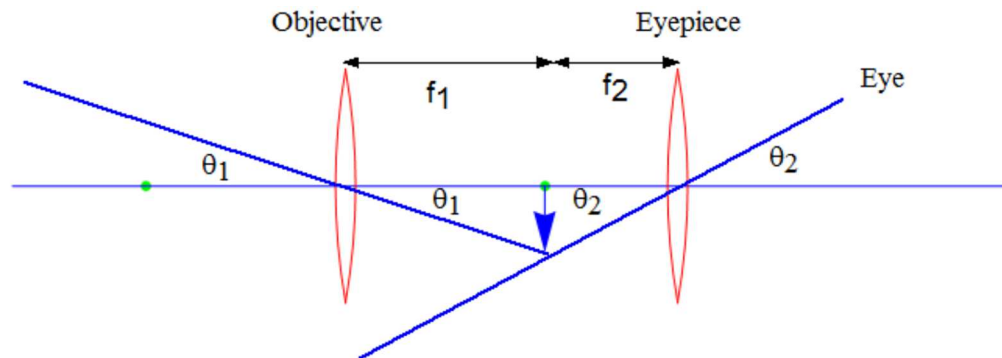

For the objective lens (f_1)

$$\frac{1}{f_1} = \frac{1}{p_1} + \frac{1}{q_1}$$

where $p_1 = \infty$. Then we have $q_1 = f_1 (>0)$. The separation distance between two lenses is

$$d = f_1 + f_2.$$

For the eyepiece (f_2)

$$\frac{1}{f_2} = \frac{1}{p_2} + \frac{1}{q_2}$$

where $p_2 = f_2$. Then we have $q_2 = -\infty$. The virtual final image is then formed at infinity and viewed by the eye.

If the intermediate image height is h , then we have

$$\tan \theta_1 = \frac{h}{f_1} \approx \theta_1 \quad \text{and} \quad \tan \theta_2 = \frac{h}{f_2} \approx \theta_2$$

The angular magnification is obtained as

$$m = \frac{\theta_2}{\theta_1} = \frac{h/f_2}{h/f_1} = \frac{f_1}{f_2}$$

((Example))

The refracting telescope at the Yerkes Observatory in Wisconsin.

$$f_1 = 20 \text{ m and } f_2 = 2.5 \text{ cm.}$$

$$m = f_1/f_2 = 20\text{m}/0.025\text{m} = 800.$$

8.3 Compound microscope

This is used for looking at small objects up close

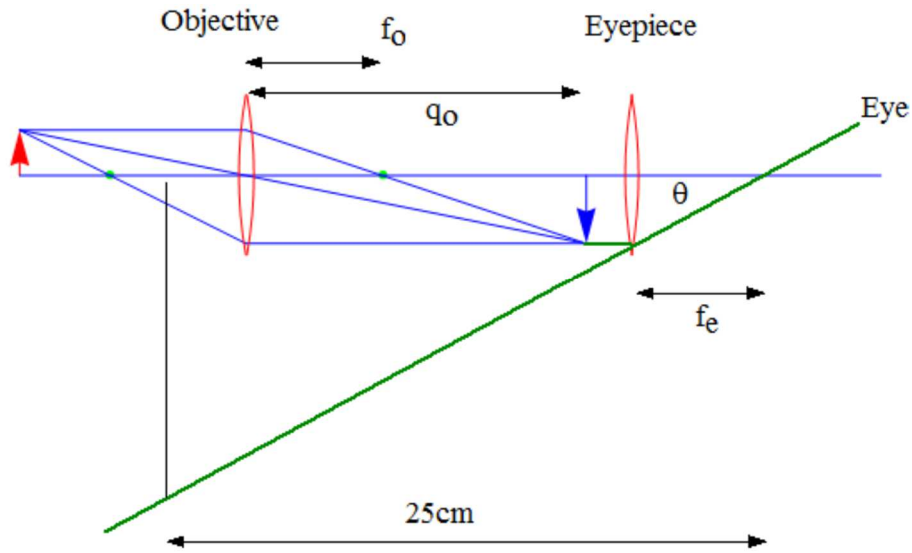

The object O to be viewed is placed just outside the first focal point f_o of the objective lens, close enough to f_o that we can approximate its distance p_o from the lens as being f_o .

$$\frac{1}{f_o} = \frac{1}{p_o} + \frac{1}{q_o}$$

where $p_o = f_o + \delta$ ($\delta > 0$).

$$\frac{1}{q_o} = \frac{1}{f_o} - \frac{1}{f_o + \delta} = \frac{\delta}{f_o(f_o + \delta)} \approx \frac{\delta}{f_o^2}$$

In the limit of $\delta \rightarrow 0$, the distance q_o is positive and becomes infinity.

The separation between the two lenses is then adjusted so that the enlarged, inverted, real image I produced by the objective lens is located just inside the focal point f_e of the eyepiece.

$$m = -\frac{q_o}{p_o} = -\frac{q_o}{f_o}$$

The eyepiece is essentially a simple magnifier used to view the second image. It provides magnification $25/f_e$ (f_e is in the units of cm). The resultant magnification of the microscope is the product of the lateral magnification m produced by the objective, and the angular magnification m_θ produced by the eyepiece,

$$M = mm_\theta = -\frac{q_o}{f_o} \frac{25\text{cm}}{f_e} \quad (\text{microscope})$$

Note that q_o is the distance from objective lens to first intermediate image, and is roughly the length of the instrument (s),

$$M = -\frac{s}{f_o} \frac{25\text{cm}}{f_e}$$

9. Electron microscope

9.1 Wavelength of electron

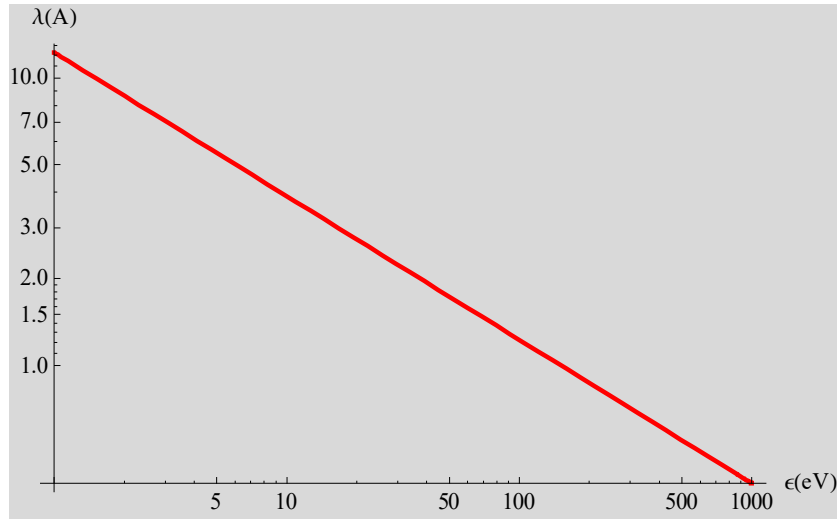

Fig. Wavelength of electron as a function of energy ϵ (eV).

The energy of an electron is related to its de Broglie wavelength λ by the energy

$$\epsilon = \frac{\hbar^2}{2m} k^2 = \frac{\hbar^2}{2m} \left(\frac{2\pi}{\lambda} \right)^2$$

where $m = 9.10938 \times 10^{-31}$ kg is the mass of the electron and $\hbar (=1.05457162853 \times 10^{-34}$ J s) is the Dirac constant. In laboratory units,

$$\lambda = \frac{12.2643}{\sqrt{\epsilon(\text{eV})}} \text{ \AA}$$

Electrons are charged and interact strongly with matter. They penetrate a relatively short distance into a crystal. Structural studies by electron diffraction are important for surfaces, films, very thin crystals, and gases.

9.4 Wavelength of photon

The energy of the photon (for example x ray) is given by

$$\varepsilon = h\nu = \frac{hc}{\lambda}$$

where h is the Planck's constant, c is the velocity of light, and λ is the wavelength. Then the wavelength λ is evaluated as

$$\lambda = \frac{1.23984}{\varepsilon(\text{keV})} \text{nm} = \frac{12.3984}{\varepsilon(\text{keV})} \text{\AA}$$

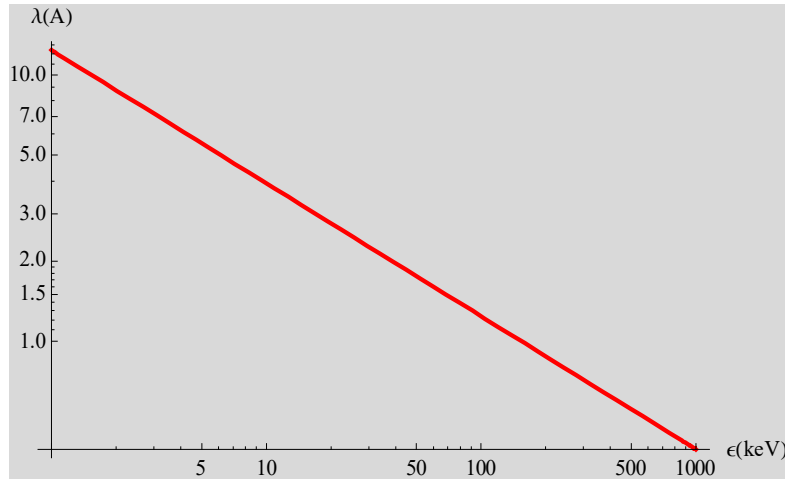

Fig. Wavelength of photon as a function of energy ε (keV).

9.5 Electron microscope

An electron microscope is a type of microscope that uses a particle beam of electrons to illuminate a specimen and create a highly-magnified image. Electron microscopes have much greater resolving power than light microscopes that use electromagnetic radiation and can obtain much higher magnifications of up to 2×10^6 times, while the best light microscopes are limited to magnifications of 2×10^3 times. Both electron and light microscopes have resolution limitations, imposed by the wavelength of the radiation they use. The greater resolution and magnification of the electron microscope is because the de Broglie wavelength of electron is much shorter than that of a photon of visible light.

The electron microscope uses electrostatic and electromagnetic lenses in forming the image by controlling the electron beam to focus it at a specific plane relative to the specimen in a manner similar to how a light microscope uses glass lenses to focus light on or through a specimen to form an image.

(a) TEM (transmission electron microscope)

TEM is a microscopy technique whereby a beam of electrons is transmitted through an ultra thin specimen, interacting with the specimen as it passes through.

(b) SEM (scanning electron microscope)

STM is a type of electron microscope that images the sample surface by scanning it with a high-energy beam of electrons.

10. Scanning tunneling microscope (STM)

Scanning tunneling microscopy (STM) is a powerful technique for viewing surfaces at the atomic level. Its development in 1981 won its inventors, Gerd Binnig and Heinrich Rohrer (at IBM Zürich), the Nobel Prize in Physics in 1986. STM probes the density of states of a material using tunneling current. For STM, good resolution is considered to be 0.1 nm lateral resolution and 0.01 nm depth resolution. The STM is based on the concept of *quantum tunneling*. When a conducting tip is brought very near to a metallic or semiconducting surface, a bias between the two can allow electrons to tunnel through the vacuum between them.

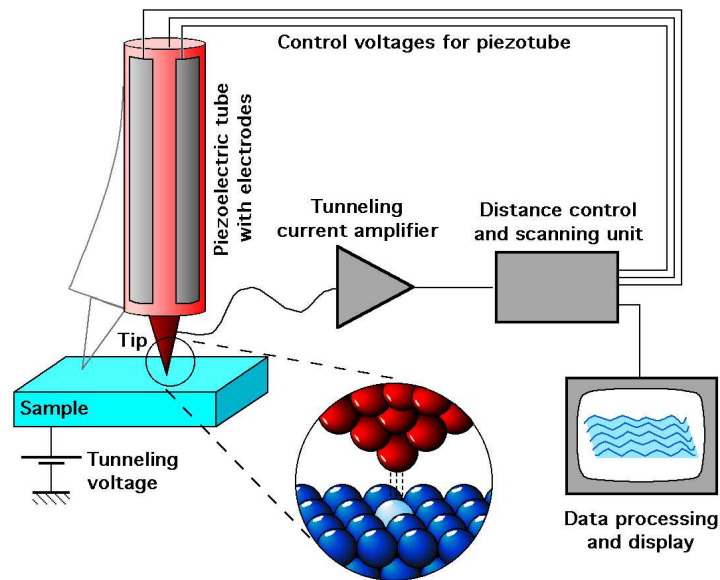

((Link)) Quantum corrals

<http://www.almaden.ibm.com/vis/stm/images/stm.gif>

Scientists discovered a new method for confining electrons to artificial structures at the nanometer length scale. Surface state electrons on Cu(111) were confined to closed structures (corrals) defined by barriers built from Fe adatoms. The barriers were assembled by individually positioning Fe adatoms using the tip of a low temperature scanning tunneling microscope (STM). A circular corral of radius 71.3 Angstrom was constructed in this way out of 48 Fe adatoms.

11. Typical examples

11.1 Problem 34-17

(a) A luminous point is moving at speed v_0 toward a spherical mirror with radius of curvature r , along the central axis of the mirror. Show that the image of this point is moving at speed

$$v_I = -\left(\frac{r}{2p - r}\right)^2 v_0$$

where p is the distance of the luminous point from the mirror at any given time. Now assume the mirror is concave, with $r = 15$ cm, and let $v_0 = 5.0$ cm/s. Find v_1 when (b) $p = 30$ cm (far outside the focal point), (c) $p = 8.0$ cm (just outside the focal point), and (d) $p = 10$ mm (very near the mirror).

((Solution))

(a)

$$\frac{1}{p} + \frac{1}{q} = \frac{1}{f} = \frac{2}{r}$$

$$q = \frac{pr}{2p - r}$$

Then

$$\frac{dq}{dt} = -\frac{r^2}{(2p - r)^2} \frac{dp}{dt}$$

$$f = 15/2 = 7.5 \text{ cm} > 0$$

$$r = 15 \text{ cm.}$$

$$\frac{dp}{dt} = 5.0 \text{ cm/s}$$

(b) $p = 30$ cm

$$\frac{dq}{dt} = -\frac{r^2}{(2p - r)^2} \frac{dp}{dt} = -\frac{15^2}{45^2} \times 5 = -\frac{5}{9} = -0.556 \text{ cm/s}$$

(c) $p = 8.0$ cm

$$\frac{dq}{dt} = -\frac{r^2}{(2p - r)^2} \frac{dp}{dt} = -\frac{15^2}{1^2} \times 5 = -1125 \text{ cm/s}$$

(d) $p = 1$ cm

$$\frac{dq}{dt} = -\frac{r^2}{(2p - r)^2} \frac{dp}{dt} = -\frac{15^2}{13^2} \times 5 = -6.657 \text{ cm/s}$$

11.2 Problem 34-49

A lens is made of glass having an index of refraction of 1.5. One side of the lens is flat, and the other is convex with a radius of curvature of 20 cm. (a) Find the focal length of the lens. (b) If an object is placed 40 cm in front of the lens, where will the image be located?

((Solution))

Lens maker's formula

$$\frac{1}{f} = (n-1)\left(\frac{1}{R_1} - \frac{1}{R_2}\right)$$

where R_1 is the radius of curvature of the lens surface near the object, and R_2 is that of the other surface. $R > 0$ when the center of curvature is on the outgoing side of the surface. $R < 0$ otherwise.

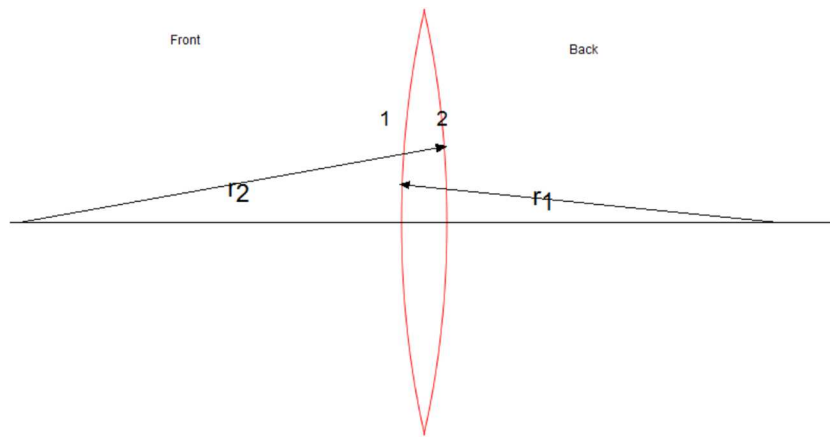

$$n = 1.50$$

$$R_2 = \infty$$

$$R_1 = 20 \text{ cm}$$

$$\frac{1}{f} = (1.50 - 1) \times \frac{1}{20}$$

(a) $f = 40 \text{ cm}$

(b)

$$\frac{1}{p} + \frac{1}{q} = \frac{1}{f}$$

When

$$p = 40 \text{ cm}, \quad f = 40 \text{ cm},$$

we have

$$q = \infty.$$

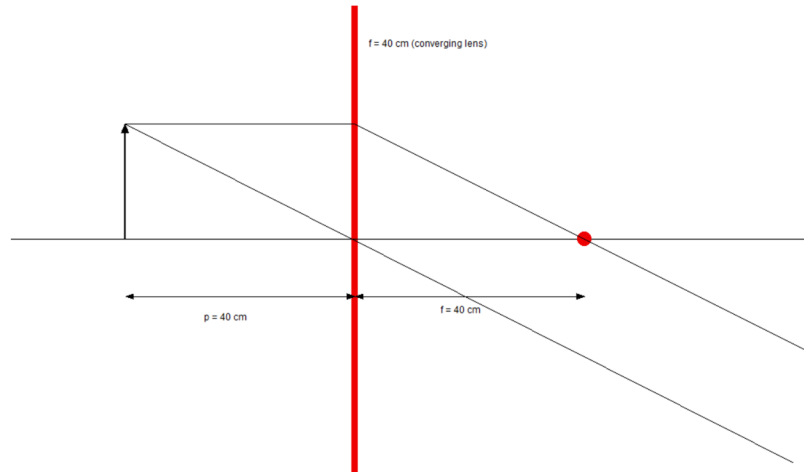

10.3 Problem 34-98

In Fig., an object is placed in front of a converging lens at a distance equal to twice the focal length f_1 of the lens. On the other side of the lens is a concave mirror of focal length f_2 separated from the lens by a distance $2(f_1 + f_2)$. Light from the object passes rightward through the lens, reflects from the mirror, passes leftward through the lens, and forms a final image of the object. What are (a) the distance between the lens and that final image and (b) the overall lateral magnification M of the object? Is the image (c) real or virtual (if it is virtual, it requires someone looking through the lens toward the mirror), (d) to the left or right of the lens, and (e) inverted or noninverted relative to the object?

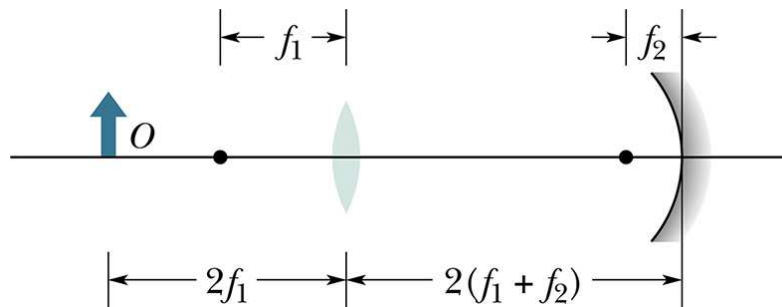

((Solution))

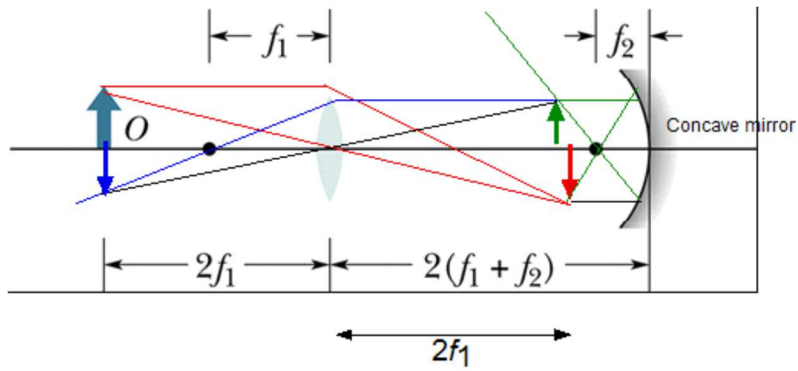

Concave mirror

(i)

$$\frac{1}{p_1} + \frac{1}{q_1} = \frac{1}{f_1}$$

$$p_1 = 2f_1$$

$$q_1 = 2f_1 > 0$$

$$m_1 = -\frac{q_1}{p_1} = -\frac{2f_1}{2f_1} = -1$$

(ii)

$$\frac{1}{p_2} + \frac{1}{q_2} = \frac{1}{f_2}$$

$$q_2 = 2f_2 > 0$$

$$m_2 = -\frac{q_2}{p_2} = -\frac{2f_1}{2f_1} = -1$$

(iii)

$$\frac{1}{p_3} + \frac{1}{q_3} = \frac{1}{f_1}$$

$$p_3 = 2f_1$$

$$q_3 = 2f_1 > 0$$

$$m_3 = -\frac{q_3}{p_3} = -\frac{2f_1}{2f_1} = -1$$

$$m = m_1 m_2 m_3 = (-1)^3 = -1$$

(a) Lens and final image $2f_1$ the same position

- (b) $m = -1$
- (c) Image (real)
- (d) Left
- (e) inverted

10.4 Problem 34-128

A small cup of green tea is positioned on the central axis of a spherical mirror. The lateral magnification of the cup is $+0.250$, and the distance between the mirror and its focal point is 2.00 cm . (a) What is the distance between the mirror and the image it produces? (b) Is the focal length positive or negative? (c) Is the image real or virtual?

((Solution))

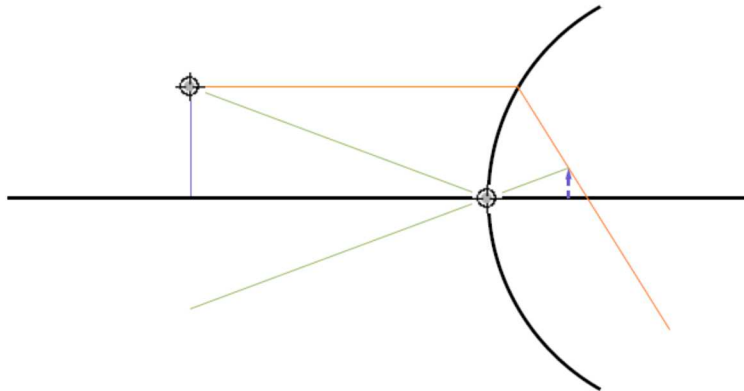

$$m = -\frac{q}{p} = \frac{1}{4}, \quad |f| = 2.00\text{cm}$$

$$\frac{1}{p} + \frac{1}{q} = \frac{1}{f}$$

$$\frac{1}{p} - \frac{4}{p} = -\frac{3}{p} = \frac{1}{f} < 0$$

Then we have $f = -\frac{p}{3} = -2\text{cm}$, or $p = 6\text{ cm}$ and $q = -\frac{6}{4} = -1.5\text{cm}$. Since $m > 0$, the image is upright.

- (b) $f = -2\text{cm}$. The spherical mirror is convex.
- (c) Since $q < 0$, the image is virtual.

APPENDIX
Combinations of four lenses
((Example))

